

HARYANA STATE BOARD OF TECHNICAL EDUCATION



LEARNING TEXT BOOKLET

(PHYSICS)

DIPLOMA 1ST YEAR

(January, 2019)

Developed By

**Haryana State Board of
Technical Education,
Bays 7-12, Sector 4,
Panchkula**

In collaboration with

**National Institute of Technical
Teachers Training & Research,
Sector-26,
Chandigarh**

PREFACE

Technical Education in polytechnics plays a very vital role in human resource development of the country by creating skilled manpower, enhancing industrial productivity and improving the quality of life. The aim of the polytechnic education in particular is to create a pool of skill based manpower to support shop floor and field operations as a bridge between technician and engineers. Moreover, a small and medium scale industry prefers to employ diploma holders because of their special skills in reading and interpreting drawings, estimating, costing and billing, supervision, measurement, testing, repair, maintenance etc.

Despite the plethora of opportunities available for the diploma pass-out students, the unprecedented expansion of the technical education sector in recent years has brought in its wake questions about the quality of education imparted. Moreover, during the last few years the students seeking admissions in the polytechnics are coming mainly from the rural background and face the major challenge of learning and understanding the technical contents of various subjects in English Language.

The major challenge before the Haryana State Board of Technical Education is to ensure the quality of a technical education to the stakeholders along its expansion. In order to meet the challenges and requirement of future technical education manpower, consistent efforts are made by Haryana State Board of Technical Education to design need based diploma programmes in collaboration with National Institute of Technical Teachers Training and Research, Chandigarh as per the new employment opportunities.

The Board undertook the development of the learning material tailored to match the curriculum content. This learning Text Booklet shall provide a standard material to the teachers and students to aid their learning and achieving their study goals.

Secretary
HSBTE, Panchkula

ACKNOWLEDGEMENTS

The Haryana State Board of Technical Education, Panchkula acknowledges the assistance and guidance provided by the administrative authorities of the Technical Education Department and Director, NITTTR for initiating and supporting the development of Learning Textbook for 1st year diploma students. The academic inputs from the faculty of the polytechnics for preparing the contents of Learning Textbook are duly appreciated. Thanks are also due towards the academic experts from the various Institutes of importance like NITTTR, Chandigarh; Panjab University, Chandigarh; PEC, Chandigarh etc. for their efforts in enrichment and finalization of the contents of this learning textbook. Last but not the least the efforts of the coordinators for overall monitoring, coordinating the development of the Learning Textbook and organization of workshops are also duly acknowledged.

**Joint Secretary
HSBTE, Panchkula**

TEAM INVOLVED IN DEVELOPMENT OF LEARNING TEXTBOOK (PHYSICS)

ADMINISTRATIVE AUTHORITIES

1. Sh. Anil Kumar, IAS, Additional Chief Secretary, Technical Education, Govt. of Haryana-Cum-Chairman, Haryana State Board of Technical Education, Panchkula
2. Sh. A. Sreeniwas, IAS, Director General, Technical Education, Govt. of Haryana
3. Sh. K. K. Kataria, Director, Technical Education-Cum-Secretary, Haryana State Board of Technical Education, Panchkula
4. Dr. S.S. Pattnaik, Director, National Institute of Technical Teachers Training and Research, Chandigarh

POLYTECHNIC FACULTY

5. Dr. Bhajan Lal, Lecturer Physics, Govt. Polytechnic for Women, Sirsa
6. Sh. Anil Nain, Lecturer Physics, Govt. Polytechnic, Hisar
7. Smt. Bindu Verma, Lecturer Physics, SJPP Damla
8. Dr. Sarita Maan, Lecturer Physics, Govt. Polytechnic, Ambala City
9. Sh. Arvind Kumar, Lecturer Physics, Govt. Polytechnic, Mandi Adampur
10. Dr. Anoop Kumar, Lecturer Physics, Govt. Polytechnic for Women, Faridabad

ACADEMIC EXPERTS

11. Dr. S.K. Tripathi, Professor of Physics, Physics Department, Panjab University, Chandigarh
12. Dr. Sanjeev Kumar, Professor, Applied Physics, Applied Science Dept., Punjab Engineering College, Chandigarh

COORDINATORS

13. Dr. B. C. Choudhary, Professor, Applied Physics, Applied Science Dept., NITTTR, Chandigarh
14. Sh. R. K. Miglani, Joint Secretary (Academics), Haryana State Board of Technical Education, Panchkula
15. Dr. Nidhi Aggarwal, Assistant Secretary, Haryana State Board of Technical Education, Panchkula
16. Sh. Sanjeev Kumar, Assistant Secretary, Haryana State Board of Technical Education, Panchkula
17. Sh. D. K. Rawat, Principal, Govt. Polytechnic, Narnaul

INDEX

CHAPTER NO.	TITLE	PAGE NO.
	SYLLABUS	i-iii
	DISTRIBUTION OF SYLLABUS & MARKS FOR ASSESSMENTS	iv-vii
1.	UNITS AND DIMENSIONS	1-14
2.	FORCE AND MOTION	15-24
3.	WORK, POWER AND ENERGY	25-30
4.	ROTATIONAL MOTION	31-35
5.	PROPERTIES OF MATTER	36-40
6.	HEAT AND TEMPERATURE	41-46
7.	WAVE MOTION AND ITS APPLICATIONS	47-59
8.	OPTICS	60-67
9.	ELECTROSTATICS	68-76
10.	CURRENT ELECTRICITY	77-86
11.	ELECTROMAGNETISM	87-91
12.	SEMICONDUCTOR PHYSICS	92-100
13.	MODERN PHYSICS	101-107
	ASSIGNMENTS AND SAMPLE PAPERS	108-112

SYLLABUS

1.3 APPLIED PHYSICS

L T P
2 1 2

RATIONALE

Applied physics includes the study of a large number of diverse topics all related to things that go on in the world around us. It aims to give an understanding of this world both by observation and by prediction of the way in which objects will behave. Concrete use of physical principles and analysis in various fields of engineering and technology are given prominence in the course content.

Note: Teachers should give examples of engineering/technology applications of various concepts and principles in each topic so that students are able to appreciate learning of these concepts and principles. In all contents, SI units should be followed. Working in different sets of units can be taught through relevant software.

LEARNING OUTCOMES

After undergoing this subject, the students will be able to:

- Identify physical quantities, parameters and select their units for use in engineering solutions.
- Units and dimensions of different physical quantities.
- Represent physical quantities as scalar and vectors.
- Basic laws of motions,
- Analyse and design banking of roads and apply conservation of momentum to explain recoil of gun etc.
- Define work, energy and power and their units. Solve problems about work and power
- State the principle of conservation of energy.
- Identify forms of energy, conversion from one form to another.
- Compare and contrast the physical properties associated with linear motion and rotational motion and give examples of conservation of angular momentum.
- Describe the surface tension phenomenon and its units, applications, effects of temperature on surface tension.
- Describe the viscosity of liquids.
- Define stress and strain, modulus of elasticity.
- State Hooke's law.
- Measure temperature in various processes on different scales (Celsius, Kelvin, Fahrenheit etc.)
- Distinguish between conduction, convection and radiation.
- Use equipment like, Vernier calliper, Screw Gauge, Spherometer.
- Differentiate between Transverse and Longitudinal, Periodic and Simple Harmonic Motion.

- Explain the terms: frequency, amplitude, wavelength, wave velocity, frequency and relation between them.
- Explain various Engineering and Industrial applications of Ultrasonics.
- Apply acoustics principles to various types of buildings to get best sound effect.
- Explain the laws of reflection and refraction of light.
- Explain total internal reflection as applied to optical fibers.
- Define capacitance and its unit and solve simple problems using $C=Q/V$
- Explain the role of free electrons in insulators, conductors and semiconductors.
- Application of semiconductors as diode, rectifiers, concept of transistors
- Explain electric current as flow of charge, the concept of resistance, heating effect of current.
- State and apply Ohm's law.
- Calculate the equivalent resistance of a variety of resistor combinations.
- Apply the concept of light amplification in designing of various LASER based instruments and optical sources.
- Apply the use of optical fibre in Medical field and optical fibre Communication.
- Concept of nanomaterials

LIST OF PRACTICALS (To perform minimum fourteen experiments)

1. To find diameter of solid cylinder using a vernier calliper
2. To find internal diameter and depth of a beaker using a vernier calliper and hence find its volume.
3. To find the diameter of wire using screw gauge
4. To find thickness of paper using screw gauge.
5. To determine the thickness of glass strip using a spherometer
6. To determine radius of curvature of a given spherical surface by a spherometer.
7. To verify parallelogram law of forces
8. To determine the atmospheric pressure at a place using Fortin's barometer
9. To determine force constant of spring using Hooke's law
10. Measuring room temperature with the help of thermometer and its conversion in different scale.
11. To find the time period of a simple pendulum
12. To determine and verify the time period of cantilever
13. To verify ohm's laws by plotting a graph between voltage and current.
14. To verify laws of resistances in series combination.
15. To verify laws of resistance in parallel combination.
16. To find resistance of galvanometer by half deflection method
17. To verify laws of reflection of light using mirror.
18. To verify laws of refraction using glass slab.
19. To find the focal length of a concave lens, using a convex lens
20. To study colour coding scheme of resistance.

INSTRUCTIONAL STRATEGY

Teacher may use various teaching aids like models, charts, graphs and experimental kits etc. for imparting effective instructions in the subject. Students need to be exposed to use of different sets of units and conversion from one unit type to another. Software may be used to solve problems involving conversion of units. The teacher should explain about field applications before teaching the basics of mechanics, work, power and energy, rotational motion, properties of matter etc. to develop proper understanding of the physical phenomenon. Use of demonstration can make the subject interesting and develop scientific temper in the students.

MEANS OF ASSESSMENT

- Assignments and quiz/class tests, mid-term and end-term written tests, model/prototype
- Actual laboratory and practical work, exercises and viva-voce

RECOMMENDED BOOKS

1. Text Book of Physics for Class XI (Part-I, Part-II); N.C.E.R.T., Delhi
2. Applied Physics, Vol. I and Vol. II by Dr. H H Lal; TTTI Publications, Tata McGraw Hill, Delhi
3. Applied Physics - I& II by AS Vasudeva; Modern Publishers, Jalandhar.
4. Applied Physics - I& II by R A Banwait; Eagle Prakashan, Jalandhar.
5. A text book of OPTICS by N Subrahmanyam, Brij Lal and Avadhanulu; S Chand Publishing, New Delhi.
6. e-books/e-tools/relevant software to be used as recommended by AICTE/ HSBTE/ NITTTR.
7. Nanotechnology: Importance and Applications by M H Fulekar; IK International Publishing House (P) Ltd., New Delhi.
8. Practical Physics, by C. L. Arora, S Chand Publication

Websites for Reference:

<http://swayam.gov.in>

Distribution of Syllabus and Marks for Assessments

Section A (20%)

1. **Units and Dimensions** (08 periods)
 - 1.1 Definition of Physics, physical quantities (fundamental and derived),
 - 1.2 Units: fundamental and derived units,
 - 1.3 Systems of units: CGS, FPS, MKS, SI
 - 1.4 Definition of dimensions;
 - 1.5 Dimensional formulae and SI units of physical quantities (distance, displacement, area, volume, velocity, acceleration, momentum, force, impulse, work, power, energy, pressure, surface tension, stress, strain)
 - 1.6 Principle of homogeneity of dimensions
 - 1.7 Dimensional equations, applications of dimensional equations; checking of correctness of equation, conversion of system of unit (force, work)

2. **Force and Motion** (08 periods)
 - 2.1 Scalar and vector quantities (definition and examples),
 - 2.2 Addition of vectors, triangle & parallelogram law (statement only),
 - 2.3 Scalar and vector product (statement and formula only)
 - 2.4 Definition of distance, displacement, speed, velocity, acceleration
 - 2.5 Force and its units, concept of resolution of force
 - 2.6 Newton's law of motion (statement and examples),
 - 2.7 Linear momentum, conservation of momentum (statement only), Impulse
 - 2.8 **Circular motion:** definition of angular displacement, angular velocity, angular acceleration, frequency, time period; relation between linear and angular velocity.
 - 2.9 Centripetal and centrifugal forces (definition and formula only)
 - 2.10 Application of centripetal force in banking of roads (derivation for angle of banking)

Section B (20%)

3. **Work, Power and Energy** (05 periods)
 - 3.1. Work (definition, symbol, formula and SI units)
 - 3.2. Energy (definition and its SI units), examples of transformation of energy.
 - 3.3. Kinetic energy (formula, examples and its derivation)
 - 3.4. Potential energy (formula, examples and its derivation)
 - 3.5. Law of conservation of mechanical energy for freely falling bodies (with derivation)
 - 3.6. Power (definition, formula and units)
 - 3.7. Simple numerical problems based on formula of power

4. **Rotational Motion** (03 periods)
 - 4.1 Rotational motion with examples

- 4.2 Definition of torque and angular momentum and their examples
- 4.3 Conservation of angular momentum (quantitative) and its examples
- 4.4 Moment of inertia and its physical significance, radius of gyration (definition, derivation and formula).

5. Properties of Matter (06 periods)

- 5.1 Definition of elasticity, deforming force, restoring force, example of Elastic and plastic body,
- 5.2 Definition of stress and strain with their types,
- 5.3 Hooke's law, modulus of elasticity (Young's, bulk modulus and shear)
- 5.4 Pressure (definition, formula, unit), Pascals Law
- 5.5 Surface tension: definition, its units, applications of surface tension, effect of temperature on Surface tension
- 5.6 Viscosity: definition, units, effect of temperature on viscosity
- 5.7 Fluid motion, stream line and turbulent flow.

Section C (60%)

6. Heat and Temperature (04 periods)

- 6.1 Definition of heat and temperature (on the basis of kinetic theory),
- 6.2 Difference between heat and temperature
- 6.3 Principles of measurement of temperature.
- 6.4 Modes of transfer of heat (conduction, convection and radiation with examples).
- 6.5 Properties of heat radiation
- 6.6 Different scales of temperature and their relationship

7. Wave motion and its applications (07 periods)

- 7.1 Wave motion, transverse and longitudinal wave motion with examples, Terms used in wave motion like displacement, amplitude, time period, frequency, wavelength, wave velocity; relationship among wave velocity, frequency and wave length .
- 7.2 Simple harmonic motion (SHM): definition, examples
- 7.3 Cantilever (definition, formula of time period (without derivation).
- 7.4 Free, forced and resonant vibrations with examples
- 7.5 Acoustics of buildings– reverberation, reverberation time, echo, noise, coefficient of absorption of sound, methods to control reverberation time.
- 7.6 Ultrasonics: Introduction and their engineering applications (cold welding, drilling, SONAR)

8. Optics (03 periods)

- 8.1. Reflection and refraction with laws, refractive index, lens formula (no derivation), power of lens (related numerical problems).

- 8.2. Total internal reflection and its applications, critical angle and conditions for total internal reflection
- 8.3. Microscope, telescope (definition)
- 8.4. Uses of microscope and telescope.

9. Electrostatics (06 Periods)

- 9.1. Electric charge, unit of charge, conservation of charge.
- 9.2. Coulombs law of electrostatics,
- 9.3. Electric field, electric lines of force (definition and properties), electric field intensity due to a point charge.
- 9.4. Definition of electric flux, Gauss law (Statement and derivation)
- 9.5. Capacitor and capacitance (with formula and units), series and parallel combination of capacitors (simple numerical problems)

10. Current Electricity (06 Periods)

- 10.1 Electric Current and its unit, direct and alternating current,
- 10.2 Resistance, specific resistance and conductance (definition and units)
- 10.3 Series and parallel combination of resistances.
- 10.4 Ohm's law (statement and formula),
- 10.5 Heating effect of current, electric power and its units
- 10.6 Kirchhoff's laws (statement and formula)

11 Electromagnetism (03 periods)

- 11.1. Introduction to magnetism, types of magnetic materials. Dia, para and ferromagnetic materials with examples.
- 11.2. Magnetic field, magnetic intensity, magnetic lines of force, magnetic flux and their units
- 11.3. Electromagnetic induction (definition)

12. Semiconductor physics (07 periods)

- 12.1. Definition of energy level, energy bands,
- 12.2. Types of materials (insulator, semiconductor, conductor) with examples,
- 12.3. Intrinsic and extrinsic semiconductors, p-n junction diode and its V-I characteristics
- 12.4. Diode as rectifier – half wave and full wave rectifier (centre tap only)
- 12.5. Semiconductor transistor; pnp and npn (Introduction only), symbol.

13. Modern Physics (06 periods)

- 13.1. Lasers: full form, principle, spontaneous emission, stimulated emission, population inversion, engineering and medical applications of lasers.
- 13.2. Fibre optics: Introduction to optical fibers (definition, parts), applications of optical fibers in different fields.
- 13.3. Introduction to nanotechnology (definition of nanomaterials with examples) and its applications.

DISTRIBUTION OF MARKS

Section	Unit	Time Allotted (Periods)	Marks Allotted (%)
A (20 Marks)	1	8	10
	2	8	10
B (20 Marks)	3	5	8
	4	3	4
	5	6	8
C (60 Marks)	6	4	6
	7	7	10
	8	3	5
	9	6	9
	10	6	8
	11	3	4
	12	7	9
	13	6	9
	Total	72	100

Chapter 1

UNITS AND DIMENSIONS

Learning objective: After going through this chapter, students will be able to;

- *Understand physical quantities, fundamental and derived;*
- *Describe different systems of units;*
- *Define dimensions and formulate dimensional formulae;*
- *Write dimensional equations and apply these to verify various formulations.*

1.1 DEFINITION OF PHYSICS AND PHYSICAL QUANTITIES

Physics: *Physics is the branch of science, which deals with the study of nature and natural phenomena.* The subject matter of physics includes heat, light, sound, electricity, magnetism and the structure of atoms.

For designing a law of physics, a scientific method is followed which includes the verifications with experiments. The physics, attempts are made to measure the quantities with the best accuracy. Thus, physics can also be defined as **science of measurement**.

Applied Physics is the application of the Physics to help human beings and solving their problem, it is usually considered as a bridge between Physics & Engineering.

Physical Quantities: *All quantities that can be measured are called physical quantities.*

For example: Distance, Speed, Mass, Force etc.

Types of Physical Quantity:

Fundamental Quantity: *The quantity which is independent of other physical quantities.* In mechanics, mass, length and time are called fundamental quantities.

Derived Quantity: *The quantity which is derived from the fundamental quantities is a derived quantity.* For example area, speed etc.

1.2 UNITS: FUNDAMENTAL AND DERIVED UNITS

Measurement: In our daily life, we need to express and compare the magnitude of different quantities; this can be done only by measuring them.

Measurement is the comparison of an unknown physical quantity with a known fixed physical quantity.

Unit: The known fixed physical quantity is called unit.

or

The quantity used as standard for measurement is called unit.

For example, when we say that length of the class room is 8 metre, we compare the length of class room with standard quantity of length called metre.

Length of class room = 8 metre

$$\boxed{Q = nu}$$

Physical Quantity = Numerical value \times unit

Q = Physical Quantity

n = Numerical value

u = Standard unit

e.g. Mass of stool = 15 kg

Mass = Physical quantity

15 = Numerical value

kg = Standard unit

Means mass of stool is 15 times of known quantity i.e. kg.

Characteristics of Standard Unit: A unit selected for measuring a physical quantity should have the following properties

- (i) It should be well defined i.e. its concept should be clear.
- (ii) It should not change with change in physical conditions like temperature, pressure, stress etc.
- (iii) It should be suitable in size; neither too large nor too small.
- (iv) It should not change with place or time.
- (v) It should be reproducible.
- (vi) It should be internationally accepted.

Classification of Units: Units can be classified into two categories.

Fundamental units: *Units of fundamental physical quantities are called Fundamental units.*

Physical Quantity	Fundamental unit
Mass	kg, gram, pound
Length	metre, centimetre, foot
Time	second

Derived units: *the units of derived physical quantity are called as derived units.*

For example units of area, speed etc.

$$\begin{aligned}\text{Area} &= \text{Length} \times \text{Breadth} \\ &= \text{Length} \times \text{Length} \\ &= (\text{Length})^2 \\ \text{Speed} &= \text{Distance} / \text{Time} \\ &= \text{Length} / \text{Time}\end{aligned}$$

1.3 SYSTEMS OF UNITS: CGS, FPS, MKS, SI

For measurement of physical quantities, the following systems are commonly used:-

- (i) **C.G.S system:** In this system, the unit of length, mass and time are centimetre, gram and second, respectively.
- (ii) **F.P.S system:** In this system, the unit of length, mass and time are foot, pound and second, respectively.
- (iii) **M.K.S:** In this system, the unit of length, mass and time are metre, kilogram and second, respectively.

(iv) **S.I System:** This system is an improved and extended version of M.K.S system of units. It is called international system of unit.

With the development of science & technology, the three fundamental quantities like mass, length & time were not sufficient as many other quantities like electric current, heat etc. were introduced. Therefore, more fundamental units in addition to the units of mass, length and time are required.

Thus, MKS system was modified with addition of four other fundamental quantities and two supplementary quantities.

Table of Fundamental Units

Sr. No.	Name of Physical Quantity	Unit	Symbol
1	Length	metre	m
2	Mass	kilogram	kg
3	Time	second	s
4	Temperature	kelvin	K
5	Electric Current	ampere	A
6	Luminous Intensity	candela	cd
7	Quantity of Matter	mole	mol

Table of Supplementary unit

Sr. No	Name of Physical Quantity	Unit	Symbol
1	Plane angle	radian	rad
2	Solid angle	steradian	sr

Advantage of S.I. system:

- (i) It is coherent system of unit i.e. the derived units of a physical quantity are easily obtained by multiplication or division of fundamental units.
- (ii) It is a rational system of units i.e. it uses only one unit for one physical quantity e.g. joule (J) is unit for all types of energies (heat, light, mechanical).
- (iii) It is metric system of units i.e. it's multiples & submultiples can be expressed in power of 10.
- (iv) It gives due representation to all branches of physics.

Definition of Basic and Supplementary Units of S.I. system

1. **Metre (m):** one metre is the length of the path travelled by light in vacuum during a time interval of $1/299\,792\,458$ of a second.
2. **Kilogram (kg) :** one kilogram is the mass of the platinum-iridium prototype which was approved by the Conférence Générale des Poids et Mesures, held in Paris in 1889, and kept by the Bureau International des Poids et Mesures.

3. **Second (s)**: one second is the duration of 9192631770 periods of the radiation corresponding to the transition between two hyperfine levels of the ground state of Cesium-133 atom.
4. **Ampere (A)** : The ampere is the intensity of a constant current which, if maintained in two straight parallel conductors of infinite length, of negligible circular cross-section, and placed 1 metre apart in vacuum, would produce between these conductors a force equal to 2×10^{-7} newton per metre of length.
5. **Kelvin (K)**: Kelvin is the fraction 1/273.16 of the thermodynamic temperature of the triple point of water.
6. **Candela (cd)**: The candela is the luminous intensity, in a given direction, of a source that emits monochromatic radiation of frequency 540×10^{12} hertz and that has a radiant intensity in that direction of 1/683 watt per steradian.
7. **Mole (mol)**: The mole is the amount of substance of a system which contains as many elementary entities as there are atoms in 0.012 kilogram of Carbon-12.

Supplementary units:

1. **Radian (rad)**: It is supplementary unit of plane angle. It is the plane angle subtended at the centre of a circle by an arc of the circle equal to the radius of the circle. It is denoted by θ .

$$\theta = l / r; l \text{ is length of the arc and } r \text{ is radius of the circle}$$

2. **Steradian (sr)**: It is supplementary unit of solid angle. It is the angle subtended at the centre of a sphere by a surface area of the sphere having magnitude equal to the square of the radius of the sphere. It is denoted by Ω .

$$\Omega = \Delta s / r^2$$

SOME IMPORTANT ABBREVIATIONS

Symbol	Prefix	Multiplier	Symbol	Prefix	Multiplier
d	deci	10^{-1}	da	deca	10^1
c	centi	10^{-2}	h	hecto	10^2
m	milli	10^{-3}	k	kilo	10^3
μ	micro	10^{-6}	M	mega	10^6
n	nano	10^{-9}	G	giga	10^9
p	pico	10^{-12}	T	tera	10^{12}
f	femto	10^{-15}	P	pecta	10^{15}
a	atto	10^{-18}	E	exa	10^{18}

Some Important Units of Length:

- 1 micron = 10^{-6} m = 10^{-4} cm
- 1 angstrom = $1 \text{ \AA} = 10^{-10}$ m = 10^{-8} cm
- 1 fermi = 1 fm = 10^{-15} m
- 1 Light year = 1 ly = 9.46×10^{15} m
- 1 Parsec = 1pc = 3.26 light year

Some conversion factor of mass:

- 1 kilogram = 2.2046 pound
- 1 pound = 453.6 gram
- 1 kilogram = 1000 gram
- 1 milligram = $1/1000$ gram = 10^{-3} gram
- 1 centigram = $1/100$ gram = 10^{-2} gram
- 1 decigram = $1/10$ gram
- 1 quintal = 100 kg
- 1 metric ton = 1000 kilogram

1.4 DEFINITION OF DIMENSIONS

Dimensions: The powers, to which the fundamental units of mass (M), length (L) and time (T) are raised, which include their nature and not their magnitude are called dimensions of a physical quantity.

For example Area = Length x Breadth
 = $[L^1] \times [L^1] = [L^2] = [M^0 L^2 T^0]$

Here the powers (0, 2, 0) of fundamental units are called dimensions of area in mass, length and time respectively.

e.g. Density = mass/volume
 = $[M]/[L^3]$
 = $[M^1 L^{-3} T^0]$

1.5 DIMENSIONAL FORMULAE AND SI UNITS OF PHYSICAL QUANTITIES

Dimensional Formula: An expression along with power of mass, length & time which indicates how physical quantity depends upon fundamental physical quantity.

e.g. Speed = Distance/Time
 = $[L^1]/[T^1] = [M^0 L^1 T^{-1}]$

It tells us that speed depends upon L & T and it does not depend upon M.

Dimensional Equation: An equation obtained by equating the physical quantity with its dimensional formula is called dimensional equation.

e.g. the dimensional equation of area, density & velocity are given as under-
Area = $[M^0 L^2 T^0]$
Density = $[M^1 L^{-3} T^0]$
Velocity = $[M^0 L^1 T^{-1}]$

Dimensional formula & SI unit of Physical Quantities

Sr. No.	Physical Quantity	Mathematical Formula	Dimensional formula	S.I unit
1	Force	Mass \times Acceleration	$[M^1L^1T^{-2}]$	newton (N)
2	Work	Force \times Distance	$[M^1L^2T^{-2}]$	joule (J)
3	Power	Work / Time	$[M^1L^2T^{-3}]$	watt (W)
4	Energy (all form)	Stored work	$[M^1L^2T^{-2}]$	joule (J)
5	Pressure, Stress	Force/Area	$[M^1L^{-1}T^{-2}]$	Nm^{-2}
6	Momentum	Mass \times Velocity	$[M^1L^1T^{-1}]$	$kgms^{-1}$
7	Moment of force	Force \times Distance	$[M^1L^2T^{-2}]$	Nm
8	Impulse	Force \times Time	$[M^1L^1T^{-1}]$	Ns
9	Strain	Change in dimension / Original dimension	$[M^0L^0T^0]$	No unit
10	Modulus of elasticity	Stress / Strain	$[M^1L^{-1}T^{-2}]$	Nm^{-2}
11	Surface energy	Energy / Area	$[M^1L^0T^{-2}]$	$joule/m^2$
12	Surface Tension	Force / Length	$[M^1L^0T^{-2}]$	N/m
13	Co-efficient of viscosity	Force \times Distance / Area \times Velocity	$[M^1L^{-1}T^{-1}]$	N/m^2
14	Moment of inertia	Mass \times (radius of gyration) ²	$[M^1L^2T^0]$	$kg\cdot m^2$
15	Angular Velocity	Angle / Time	$[M^0L^0T^{-1}]$	rad per sec
16	Frequency	1/Time period	$[M^0L^0T^{-1}]$	hertz (Hz)
17	Area	Length \times Breadth	$[M^0L^2T^0]$	m^2
18	Volume	Length \times Breadth \times Height	$[M^0L^3T^0]$	m^3
19	Density	Mass/ Volume	$[M^1L^{-3}T^0]$	kg/m^3
20	Speed or velocity	Distance/ Time	$[M^0L^1T^{-1}]$	m/s
21	Acceleration	Velocity/Time	$[M^0L^1T^{-2}]$	m/s^2
22	Pressure	Force/Area	$[M^1L^{-1}T^{-2}]$	N/m^2

Classification of Physical Quantities on the basis of dimensional analysis

1. **Dimensional Constant:** These are the physical quantities which possess dimensions and have constant (fixed) value.

e.g. Planck's constant, gas constant, universal gravitational constant etc.

2. **Dimensional Variable:** These are the physical quantities which possess dimensions but do not have fixed value.

e.g. velocity, acceleration, force etc.

3. **Dimensionless Constant:** These are the physical quantities which do not possess dimensions but have constant (fixed) value.

e.g. e , π , numbers like 1, 2, 3, 4, 5, etc.

4. **Dimensionless Variable:** These are the physical quantities which do not possess dimensions and have variable value.

e.g. angle, strain, specific gravity etc.

Example1 Derive the dimensional formula of following Quantity & write down their dimensions.

(i) Density

(ii) Power

(iii) Co-efficient of viscosity

(iv) Angle

Sol. (i) Density = mass/volume

$$= [M]/[L^3] = [M^1L^{-3}T^0]$$

(ii) Power = Work/Time

$$= \text{Force} \times \text{Distance}/\text{Time}$$

$$= [M^1L^1T^{-2}] \times [L]/[T]$$

$$= [M^1L^2T^{-3}]$$

(iii) Co-efficient of viscosity = $\frac{\text{Force} \times \text{Distance}}{\text{Area} \times \text{Velocity}}$

$$\frac{\text{Mass} \times \text{Acceleration} \times \text{Distance} \times \text{time}}{\text{length} \times \text{length} \times \text{Displacement}}$$

$$= [M] \times [LT^{-2}] \times [L] [T]/[L^2] \times [L]$$

$$= [M^1L^{-1}T^{-1}]$$

(v) Angle = arc (length)/radius (length)

$$= [L]/[L]$$

$$= [M^0L^0T^0] = \text{No dimension}$$

Example2 Explain which of the following pair of physical quantities have the same dimension:

(i) Work & Power (ii) Stress & Pressure (iii) Momentum & Impulse

Sol. (i) Dimension of work = force \times distance = $[M^1L^2T^{-2}]$

Dimension of power = work / time = $[M^1L^2T^{-3}]$

Work and Power have not the same dimensions.

(ii) Dimension of stress = force / area = $[M^1L^1T^{-2}]/[L^2] = [M^1L^{-1}T^{-2}]$

Dimension of pressure = force / area = $[M^1L^1T^{-2}]/[L^2] = [M^1L^{-1}T^{-2}]$

Stress and pressure have the same dimension.

(iii) Dimension of momentum = mass x velocity = $[M^1L^1T^{-1}]$

Dimension of impulse = force x time = $[M^1L^1T^{-1}]$

Momentum and impulse have the same dimension.

1.6 PRINCIPLE OF HOMOGENEITY OF DIMENSIONS

It states that *the dimensions of all the terms on both sides of an equation must be the same*. According to the principle of homogeneity, the comparison, addition & subtraction of all physical quantities is possible only if they are of the same nature i.e., they have the same dimensions.

If the power of M, L and T on two sides of the given equation are same, then the physical equation is correct otherwise not. Therefore, this principle is very helpful to check the correctness of a physical equation.

Example: A physical relation must be dimensionally homogeneous, i.e., all the terms on both sides of the equation must have the same dimensions.

In the equation, $S = ut + \frac{1}{2} at^2$

The length (S) has been equated to velocity (u) & time (t), which at first seems to be meaningless, But if this equation is dimensionally homogeneous, i.e., the dimensions of all the terms on both sides are the same, then it has physical meaning.

Now, dimensions of various quantities in the equation are:

Distance, $S = [L^1]$

Velocity, $u = [L^1T^{-1}]$

Time, $t = [T^1]$

Acceleration, $a = [L^1T^{-2}]$

$\frac{1}{2}$ is a constant and has no dimensions.

Thus, the dimensions of the term on L.H.S. is $S=[L^1]$ and

Dimensions of terms on R.H.S=

$$ut + \frac{1}{2} at^2 = [L^1T^{-1}] [T^1] + [L^1T^{-2}] [T^2] = [L^1] + [L^1]$$

Here, the dimensions of all the terms on both sides of the equation are the same.

Therefore, the equation is dimensionally homogeneous.

1.7 DIMENSIONAL EQUATIONS, APPLICATIONS OF DIMENSIONAL EQUATIONS

Dimensional Analysis: A careful examination of the dimensions of various quantities involved in a physical relation is called dimensional analysis. The analysis of the dimensions of a physical quantity is of great help to us in a number of ways as discussed under the uses of dimensional equations.

Uses of dimensional equation: The principle of homogeneity & dimensional analysis has put to the following uses:

- (i) Checking the correctness of physical equation.
- (ii) To convert a physical quantity from one system of units into another.
- (iii) To derive relation among various physical quantities.

1. **To check the correctness of Physical relations:** According to principle of Homogeneity of dimensions, a physical relation or equation is correct, if the dimensions of all the terms on both sides of the equation are the same. If the dimension of even one term differs from those of others, the equation is not correct.

Example 3 Check the correctness of the following formulae by dimensional analysis.

(i) $F = mv^2/r$ (ii) $t = 2\pi\sqrt{l/g}$

Where all the letters have their usual meanings

Sol. $F = mv^2/r$

Dimensions of the term on L.H.S

Force, $F = [M^1L^1T^{-2}]$

Dimensions of the term on R.H.S

$$\begin{aligned} mv^2/r &= [M^1][L^1T^{-1}]^2 / [L] \\ &= [M^1L^2T^{-2}] / [L] \\ &= [M^1L^1T^{-2}] \end{aligned}$$

The dimensions of the term on the L.H.S are equal to the dimensions of the term on R.H.S. Therefore, the relation is correct.

(ii) $t = 2\pi\sqrt{l/g}$

Here, Dimension of term on L.H.S

$$t = [T^1] = [M^0L^0T^1]$$

Dimensions of terms on R.H.S

Dimension of length = $[L^1]$

Dimension of g (acc. due to gravity) = $[L^1T^{-2}]$

2π being constant have no dimensions.

Hence, the dimensions of terms $t = 2\pi\sqrt{l/g}$ on R.H.S

$$= (L^1 / L^1T^{-2})^{1/2} = [T^1] = [M^0L^0T^1]$$

Thus, the dimensions of the terms on both sides of the relation are the same i.e., $[M^0L^0T^1]$. Therefore, the relation is correct.

Example 4 Check the correctness of the following equation on the basis of dimensional

analysis, $v = \sqrt{\frac{E}{d}}$. Here v is the velocity of sound, E is the elasticity and d is the density of the medium.

Sol. Here, Dimension of the term on L.H.S

$$v = [M^0L^1T^{-1}]$$

Dimension of elasticity, $E = [M^1L^{-1}T^{-2}]$
 & Dimension of density, $d = [M^1L^{-3}T^0]$
 Therefore, dimensions of the terms on R.H.S

$$v = \sqrt{\frac{E}{d}} = [M^1L^{-1}T^{-2} / M^1L^{-3}T^0]^{1/2} = [M^0L^1T^{-1}]$$

Thus, dimensions on both sides are the same, hence the equation is correct.

Example 5 Using Principle of Homogeneity of dimensions, check the correctness of equation, $h = 2Td / r g \cos \theta$.

Sol. The given formula is, $h = 2Td / r g \cos \theta$.

Dimension of term on L.H.S

$$\text{Height (h)} = [M^0L^1T^0]$$

Dimensions of terms on R.H.S

$$T = \text{surface tension} = [M^1L^0T^{-2}]$$

$$d = \text{density} = [M^1L^{-3}T^0]$$

$$r = \text{radius} = [M^0L^1T^0]$$

$$g = \text{acc. due to gravity} = [M^0L^1T^{-2}]$$

$$\cos \theta = [M^0L^0T^0] = \text{no dimensions}$$

$$\text{So, the dimensions of } 2Td / r g \cos \theta = [M^1L^0T^{-2}] \times [M^1L^{-3}T^0] / [M^0L^1T^0] \times [M^0L^1T^{-2}] \\ = [M^2L^{-5}T^0]$$

Dimensions of terms on L.H.S are not equal to dimensions on R.H.S. Hence, formula is not correct.

Example 6 Check the accuracy of the following relations:

$$(i) \quad E = mgh + \frac{1}{2} mv^2; \quad (ii) \quad v^3 - u^2 = 2as^2.$$

$$\text{Sol. (i) } E = mgh + \frac{1}{2} mv^2$$

Here, dimensions of the term on L.H.S.

$$\text{Energy, } E = [M^1L^2T^{-2}]$$

Dimensions of the terms on R.H.S,

$$\text{Dimensions of the term, } mgh = [M] \times [LT^{-2}] \times [L] = [M^1L^2T^{-2}]$$

$$\text{Dimensions of the term, } \frac{1}{2} mv^2 = [M] \times [LT^{-1}]^2 = [M^1L^2T^{-2}]$$

Thus, dimensions of all the terms on both sides of the relation are same; therefore, the relation is correct.

(ii) The given relation is,

$$v^3 - u^2 = 2as^2$$

Dimensions of the terms on L.H.S

$$v^3 = [M^0] \times [LT^{-1}]^3 = [M^0L^3T^{-3}]$$

$$u^2 = [M^0] \times [LT^{-1}]^2 = [M^0L^2T^{-2}]$$

Dimensions of the terms on R.H.S

$$2as^2 = [M^0] \times [LT^{-2}] \times [L]^2 = [M^0L^3T^{-2}]$$

Substituting the dimensions in the relations, $v^3 - u^2 = 2as^2$

$$\text{We get, } [M^0L^3T^{-3}] - [M^0L^2T^{-2}] = [M^0L^3T^{-2}]$$

The dimensions of all the terms on both sides are not same; therefore, the relation is not correct.

Example 7 The velocity of a particle is given in terms of time t by the equation

$$v = at + \frac{b}{t+c}$$

What are the dimensions of a , b and c ?

Sol. Dimensional formula for L.H.S

$$V = [L^1T^{-1}]$$

In the R.H.S dimensional formula of at

$$[T] = [L^1T^{-1}]$$

$$a = [LT^{-1}] / [T^{-1}] = [L^1T^{-2}]$$

$t+c$ = time, c has dimensions of time and hence is added in t .

Dimensions of $t+c$ is $[T]$

Now,
$$\frac{b}{t+c} = v$$

$$b = v(t+c) = [LT^{-1}][T] = [L]$$

There dimensions of $a = [L^1T^{-2}]$, dimensions of $b = [L]$ and that of $c = [T]$

Example 8 In the gas equation $(P + a/v^2)(v - b) = RT$, where T is the absolute temperature, P is pressure and v is volume of gas. What are dimensions of a and b ?

Sol. Like quantities are added or subtracted from each other i.e.

$$(P + a/v^2) \text{ has dimensions of pressure} = [ML^{-1}T^{-2}]$$

Hence, a/v^2 will be dimensions of pressure = $[ML^{-1}T^{-2}]$

$$a = [ML^{-1}T^{-2}][\text{volume}]^2 = [ML^{-1}T^{-2}][L^3]^2$$

$$a = [ML^{-1}T^{-2}][L^6] = [ML^5T^{-2}]$$

Dimensions of $a = [ML^5T^{-2}]$

$(v - b)$ have dimensions of volume i.e.,

b will have dimensions of volume i.e., $[L^3]$

$$\text{or } [M^0L^3T^0]$$

2. To convert a physical quantity from one system of units into another.

Physical quantity can be expressed as

$$Q = nu$$

Let n_1u_1 represent the numerical value and unit of a physical quantity in one system and n_2u_2 in the other system.

If for a physical quantity Q ; $M_1L_1T_1$ be the fundamental unit in one system and $M_2L_2T_2$ be fundamental unit of the other system and dimensions in mass, length and time in each system can be respectively a, b, c .

$$u_1 = [M_1^a L_1^b T_1^c]$$

$$u_2 = [M_2^a L_2^b T_2^c]$$

As we know

$$\begin{aligned}
 n_1 u_1 &= n_2 u_2 \\
 n_2 &= n_1 u_1 / u_2 \\
 n_2 &= n_1 \frac{[M_1^a L_1^b T_1^c]}{[M_2^a L_2^b T_2^c]} \\
 n_2 &= n_1 \left[\left(\frac{M_1}{M_2} \right)^a \left(\frac{L_1}{L_2} \right)^b \left(\frac{T_1}{T_2} \right)^c \right]
 \end{aligned}$$

While applying the above relations the system of unit as first system in which numerical value of physical quantity is given and the other as second system

Thus knowing $[M_1 L_1 T_1]$, $[M_2 L_2 T_2]$ a, b, c and n_1 , we can calculate n_2 .

Example 9 Convert a force of 1 newton to dyne.

Sol. To convert the force from MKS system to CGS system, we need the equation

$$Q = n_1 u_1 = n_2 u_2$$

$$\text{Thus } n_2 = \frac{n_1 u_1}{u_2}$$

Here $n_1 = 1$, $u_1 = 1\text{N}$, $u_2 = \text{dyne}$

$$\begin{aligned}
 n_2 &= n_1 \frac{[M_1 L_1 T_1^{-2}]}{[M_2 L_2 T_2^{-2}]} \\
 n_2 &= n_1 \left(\frac{M_1}{M_2} \right) \left(\frac{L_1}{L_2} \right) \left(\frac{T_1}{T_2} \right)^{-2} \\
 n_2 &= n_1 \left(\frac{\text{kg}}{\text{gm}} \right) \left(\frac{\text{m}}{\text{cm}} \right) \left(\frac{\text{s}}{\text{s}} \right)^{-2} \\
 n_2 &= n_1 \left(\frac{1000\text{gm}}{\text{gm}} \right) \left(\frac{100\text{cm}}{\text{cm}} \right) \left(\frac{\text{s}}{\text{s}} \right)^{-2} \\
 n_2 &= 1(1000)(100) \\
 n_2 &= 10^5
 \end{aligned}$$

Thus **1N=10⁵ dynes.**

Example 10 Convert work of 1 erg into joule.

Sol: Here we need to convert work from CGS system to MKS system

Thus in the equation

$$\begin{aligned}
 n_2 &= \frac{n_1 u_1}{u_2} \\
 n_1 &= 1 \\
 u_1 &= \text{erg (CGS unit of work)} \\
 u_2 &= \text{joule (SI unit of work)} \\
 n_2 &= \frac{n_1 u_1}{u_2}
 \end{aligned}$$

$$n_2 = n_1 \frac{M_1 L_1^2 T_1^{-2}}{M_2 L_2^2 T_2^{-2}}$$

$$n_2 = n_1 \left(\frac{M_1}{M_2} \right) \left(\frac{L_1}{L_2} \right)^2 \left(\frac{T_1}{T_2} \right)^{-2}$$

$$n_2 = n_1 \left(\frac{gm}{kg} \right) \left(\frac{cm}{m} \right)^2 \left(\frac{s}{s} \right)^{-2}$$

$$n_2 = n_1 \left(\frac{gm}{1000gm} \right) \left(\frac{cm}{100cm} \right)^2 \left(\frac{s}{s} \right)^{-2}$$

$$n_2 = 1(10^{-3})(10^{-2})^2 \quad n_2 = 10^{-7}$$

Thus, **1 erg = 10⁻⁷ joule.**

Limitations of Dimensional Equation: The method of dimensions has the following limitations:

1. It does not help us to find the value of dimensionless constants involved in various physical relations. The values, of such constants have to be determined by some experiments or mathematical investigations.
2. This method fails to derive formula of a physical quantity which depends upon more than three factors. Because only three equations are obtained by comparing the powers of M, L and T.
3. It fails to derive relations of quantities involving exponential and trigonometric functions.
4. The method cannot be directly applied to derive relations which contain more than one terms on one side or both sides of the equation, such as $v = u + at$ or $s = ut + \frac{1}{2} at^2$ etc. However, such relations can be derived indirectly.
5. A dimensionally correct relation may not be true physical relation because the dimensional equality is not sufficient for the correctness of a given physical relation.

* * * * *

EXERCISES

Fill in the blanks:

1. The dimensional formula for coefficient of friction is
2. The dimensional formula for Modulus of elasticity is
3. 10^5 fermi is equal toangstrom.
4. The unit of angular velocity is.....
5. The unit for measuring the luminous intensity is
6. The displacement of particle moving along x-axis with respect to time is $x=at+bt^2-ct^3$.
The dimension of c is

Short Answer Questions

1. Define Physics.
2. Define physical quantity.
3. Differentiate between fundamental and derived unit.
4. Write full form of the following system of units
(i) CGS (ii) FPS (iii) MKS
5. Write definition of Dimensions.
6. What is the suitable unit for measuring distance between sun and earth?
7. Write the dimensional formula of the following physical quantity -
(i) Momentum (ii) Power (iii) Surface Tension (iv) Strain (v) density
8. State principle of Homogeneity of Dimensions.
9. Write the S.I & C.G.S units of the following physical quantities-
(a) Force (b) Work
10. Write any three uses of dimensions.

Long Answer Questions

1. Check the correctness of the relation $\lambda = h /mv$; where λ is wavelength, h- Planck's constant, m is mass of the particle and v - velocity of the particle.
2. Explain different types of system of units.
3. Convert 1 dyne to newton.
4. Check the correctness of the following relation by using method of dimensions
(i) $v = u + at$
(ii) $F = mv / r^2$
(iii) $v^2 - u^2 = 2as$
5. State any four limitations of dimensional analysis.
6. Convert an acceleration of 100 m/s^2 into km/h^2 .

Chapter 2

FORCE AND MOTION

Learning objective: After going through this chapter, students will be able to

- Understand scalar and vector quantities, addition of vectors, scalar and vector products etc.
- State and apply Newton's laws of motion.
- Describe linear momentum, circular motion, application of centripetal force.

2.1 SCALAR AND VECTOR QUANTITIES

Scalar Quantities:

Scalar quantities are those quantities which have only magnitude but no direction.

Examples: Mass, length, density, volume, energy, temperature, distance, speed, electric charge, current, electric potential etc.

Vector Quantities:

Vector quantities are those quantities which are having both magnitude as well as direction.

Examples: Displacement, velocity, acceleration, force, electric intensity, magnetic intensity etc.

Representation of Vector: A vector is represented by a straight line with an arrow head. Here, the length of the line represents the magnitude and arrow head gives the direction of vector.

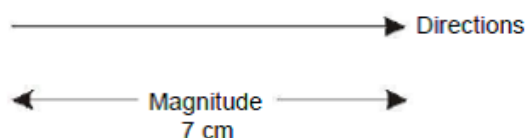

Figure: 2.1

Types of Vectors

Negative Vectors: The negative of a vector is defined as another vector having same magnitude but opposite in direction.

- i. e. any vector \vec{A} and its negative vector $[-\vec{A}]$ are shown in Fig.2.2.

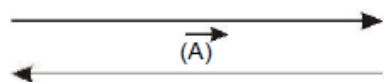

Figure: 2.2

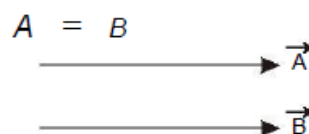

Figure: 2.3

Equal Vector: Two or more vectors are said to be equal, if they have same magnitude and same direction. If \vec{A} and \vec{B} are two equal vectors then

Unit Vector: A vector divided by its magnitude is called a unit vector. It has a magnitude one unit and direction same as the direction of given vector. It is denoted by \hat{A} (A cap).

$$\hat{A} = \frac{\vec{A}}{A}$$

Collinear Vectors: Two or more vectors having equal or unequal magnitudes, but having same direction are called collinear vectors



Figure: 2.4

Zero Vector: A vector having zero magnitude and arbitrary direction (be not fixed) is called zero vector. It is denoted by O.

2.2 LAWS OF ADDITION OF VECTORS

(i) Triangle law of vector addition.

It two vectors can be represented in magnitude and direction by the two sides of a triangle taken in the same order, then the resultant is represented in magnitude and direction, by third side of the triangle taken in the opposite order (Fig. 2.5).

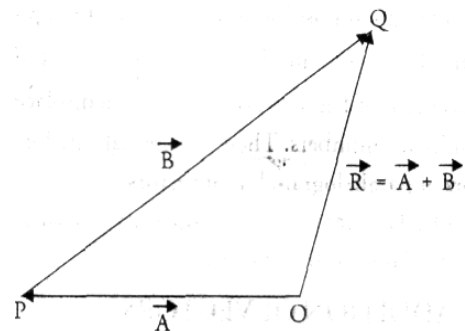

Figure: 2.5

Magnitude of the resultant is given by

$$R = \sqrt{A^2 + B^2 + 2AB \cos \theta}$$

And direction of the resultant is given by

$$\tan \beta = \frac{B \sin \theta}{A + B \cos \theta}$$

(ii) Parallelogram (||gm) law of vectors addition:

It states that if two vectors, acting simultaneously at a point, can have represented both in magnitude and direction by the two adjacent sides of a parallelogram, the resultant is represented by the diagonal of the parallelogram passing through that point (Fig. 2.6).

Magnitude of the resultant is given by

$$R = \sqrt{P^2 + Q^2 + 2PQ \cos \theta}$$

And direction of the resultant is given by

$$\tan \phi = \frac{Q \sin \theta}{P + Q \cos \theta}$$

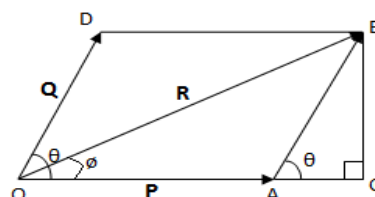

Figure: 2.6

2.3 SCALAR AND VECTOR PRODUCT

Multiplication of Vectors

(i) **Scalar (or dot) Product:** of two vectors is defined as the product of magnitude of two vectors and the cosine of the smaller angle between them. The dot product of vectors \vec{A} and \vec{B} can be represented as

$$\vec{A} \cdot \vec{B} = A B \cos \theta$$

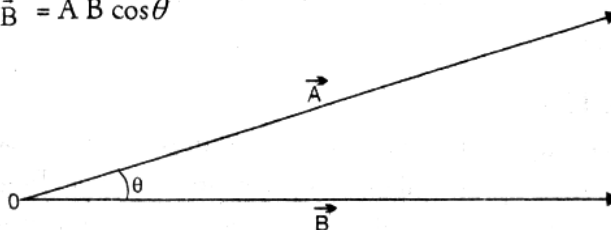

Figure: 2.7

(ii) **Vector (or Cross) Product:** of two vectors is defined as a vector having a magnitude equal to the product of the magnitudes of the two vectors and the sine of the angle between them and is in the direction perpendicular to the plane containing the two vectors.

Thus, the vector product of two vectors A and B is equal to

$$\vec{A} \times \vec{B} = AB \sin \theta \hat{n}$$

2.4 DEFINITION OF DISTANCE, DISPLACEMENT, SPEED, VELOCITY, ACCELERATION

Distance: *The path covered by an object during its motion is called distance.* Distance is a scalar quantity. SI unit is metre (m).

Displacement: *The shortest distance between the two points is called displacement.* It is a vector quantity.

SI unit is metre.

Dimension formula: [L]

Speed: *The rate of change of distance is called speed.* Speed is a scalar quantity.

$$\text{speed} = \frac{\text{distance}}{\text{time}}$$

Unit: ms^{-1} .

Linear Velocity: *The time rate of change of displacement.*

$$v = \frac{\text{change in displacement}}{\text{time}}$$

Units of Velocity: ms^{-1}

Dimension formula = $[\text{M}^0\text{L}^1\text{T}^{-1}]$

Acceleration: *The change in velocity per unit time.* i.e. the time rate of change of velocity.

$$a = \frac{\text{Change in velocity}}{\text{time}}$$

If the velocity increases with time, the acceleration 'a' is positive. If the velocity decreases with time, the acceleration 'a' is negative. Negative acceleration is also known as retardation.

Units of acceleration:

C.G.S. unit is cm/s^2 (cms^{-2}) and the SI unit is m/s^2 (ms^{-2}).

Dimension formula = $[\text{M}^0\text{L}^1\text{T}^{-2}]$

2.5 FORCE

Force: Force is an agent that produces acceleration in the body on which it acts.

Or

It is a push or a pull which change or tends to change the position of the body at rest or in uniform motion. Force is a vector quantity.

For example,

- (i) To move a football, we have to exert a push i.e., kick on the football
- (ii) To stop football or a body moving with same velocity, we have to apply push in a direction opposite to the direction of the body.

SI unit is newton.

Dimension formula: $[\text{MLT}^{-2}]$

Concept of Resolution of a Force

The phenomenon of breaking a given force into two or more forces in different directions is known as resolution of force. The forces obtained on splitting the given force are called components of the given force.

If these are at right angles to each other, then these components are called rectangular components.

Let a force F be represented by a line OP. Let OB (or F_x) is component of F along x-axis and OC (or F_y) is component along y-axis (Fig. 2.8).

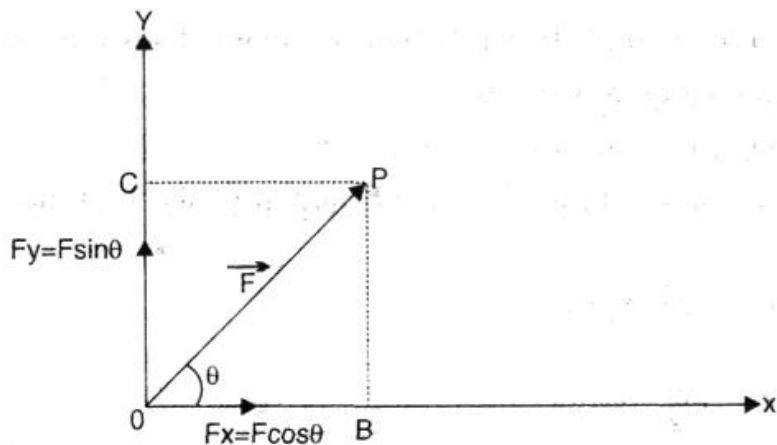

Figure: 2.8

Let force F makes an angle θ with x-axis.

In ΔOPB

$$\sin\theta = \frac{OB}{OP}$$

or $PB = OP \sin\theta$

$$F_y = F \sin\theta$$

$$\cos\theta = \frac{OB}{OP}$$

$$OB = OP \cos\theta$$

$$F_x = F \cos \theta$$

$$\text{Vector } \vec{F} = \vec{F}_x + \vec{F}_y$$

$$\text{So, resultant: } F = \sqrt{F_x^2 + F_y^2}$$

2.6 NEWTON'S LAWS OF MOTION

Sir Isaac Newton gave three fundamental laws. These laws are called Newton's laws of motion. These are

Newton's First Law: *It states that everybody continues in its state of rest or of uniform motion in a straight line until some external force is applied on it.*

For example, the book lying on a table will not move at its own. It does not change its position from the state of rest until no external force is applied on it.

Newton's Second law: *The rate of change of momentum of a body is directly proportional to the applied force and the change takes place in the direction of force applied.*

Or

Acceleration produced in a body is directly proportional to force applied.

Let us consider a body of mass m is moving with a velocity u . Let a force F be applied so that its

velocity changes from u to v in t second.

$$\text{Initial momentum} = mu$$

$$\text{Final momentum after time } t \text{ second} = mv$$

$$\text{Total change in momentum} = mv - mu.$$

Thus, the rate of change of momentum will be

$$\frac{mv - mu}{t}$$

From Newton's second law

$$F \propto \frac{mv - mu}{t} \text{ or } F \propto \frac{m(v - u)}{t}$$

$$\text{but } \frac{v - u}{t} = \frac{\text{Change in velocity}}{\text{time}} = \text{acceleration (a)}$$

Hence, we have

$$F \propto ma$$

$$\text{or } F = k ma$$

Where k is constant of proportionality, for convenience let $k = 1$.

$$\text{Then } \mathbf{F = ma}$$

Units of force:

One **dyne** is that much force which produces an acceleration of 1cm/s^2 in a mass of 1 gm.

$$1 \text{ dyne} = 1 \text{ gm} \times 1 \text{ cm/s}^2$$

$$= 1 \text{ gm cm s}^{-2}$$

One **newton** is that much force which produces an acceleration of 1 m/s^2 in a mass of 1 kg .

$$\begin{aligned}\text{Using } F &= ma \\ 1 \text{ N} &= 1 \text{ kg} \times 1 \text{ m/s}^2 \\ \text{or} &= 1 \text{ kgm/s}^2 \\ 1 \text{ N} &= 1000 \text{ gm} \times 100 \text{ cm/s}^2 = 10^5 \text{ dyne}\end{aligned}$$

Newton's Third law: it states that *to every action there is an equal and opposite reaction or action and reaction are equal and opposite.*

When a body exerts a force on another body, the other body also exerts an equal force on the first body but in opposite direction.

From Newton's third law these forces always occur in pairs. If two bodies A and B apply force on each other, then

$$F_{AB} \text{ (force on A by B)} = -F_{BA} \text{ (force on B by A)}$$

2.7 LINEAR MOMENTUM, CONSERVATION OF MOMENTUM, IMPULSE

Linear Momentum (p): *The quantity of motion contained in the body is linear momentum.* It is given by product of mass and the velocity of the body. It is a vector and its direction is the same as the direction of the velocity.

Let m be the mass and v is the velocity of a body at some instant, then its linear momentum is given by $p = mv$

Example, a fast-moving cricket ball has more momentum in it than a slow moving one. But a slow-moving heavy roller has more momentum than a fast cricket ball.

Units of momentum:

The SI unit is kg m/s i.e. kgms^{-1}
Dimension formula = $[\text{M}^1\text{L}^1\text{T}^{-1}]$

Law of conservation of Momentum

It states that if external force acting on a system of bodies is zero then the total linear momentum of a system always remains constant. As we know from Newton's second law of motion

$$F = \frac{dp}{dt}$$

i.e. If $F=0$

$$\text{Thus, } F = \frac{dp}{dt} = 0$$

Hence, p (momentum) is constant.

Application of law of conservation of momentum

Recoil of the Gun: When a bullet is fired with a gun the bullet moves in forward direction and gun is recoiled/pushed backwards. Let

m = mass of bullet
 u = velocity of bullet
 M = mass of gun
 V = velocity of gun

The gun and bullet form an isolated system, so the total momentum of gun and bullet before firing = 0

Total momentum of gun and bullet after firing = $mu + MV$

Using law of conservation of momentum

$$0 = m.u + M.v$$

$$MV = -mu$$

$$V = \frac{-mu}{M}$$

This is the expression for recoil velocity of gun.

Here negative sign shows that motion of the gun is in opposite direction to that of the bullet. Also, velocity of gun is inversely proportional to its mass. Lesser the mass, larger will be the recoil velocity of the gun.

Impulse

Impulse is defined as the total change in momentum produced by the impulsive force.

OR

Impulse may be defined as the product of force and time and is equal to the total change in momentum of the body.

$$F.t = p_2 - p_1 = \text{total change in momentum}$$

Example: A kick given to a football or blow made with hammer.

SI unit: Ns

2.8 CIRCULAR MOTION

The motion of a body in a circle of fixed radius is called circular motion.

For example, the motion of a stone tied to a string when whirled in the air is a circular motion.

Angular Displacement (θ): *The angle subtended by a body while moving in a circle is called angular displacement.*

Consider a body moves in a circle, starting from A to B so that $\angle BOA$ is called angular displacement

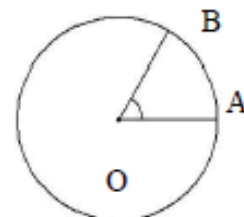

Figure: 2.9

The SI unit of angular displacement is radian (rad.)

Angular Velocity: Angular velocity of a body moving in a circle is the *rate of change of angular displacement with time*. It is denoted by ω (omega)

If θ is the angular displacement in time t then

$$\omega = \frac{\theta}{t}$$

SI unit of angular velocity is rad/s

Time Period: Time taken by a body moving in a circle to complete one cycle is called time period. It is denoted by T

Frequency (n): The number of cycles completed by a body in one second is called frequency. It is reciprocal of time period; $n = \frac{1}{T}$

Angular Acceleration: The time rate of change of angular velocity of a body.

It is denoted by α . Let angular velocity of a body moving in a circle change from ω_1 to ω_2 in time t , then

$$\alpha = \frac{\omega_1 - \omega_2}{t}$$

SI unit of ' α ' is rad/s²

Relationship between linear and angular velocity

Consider a body moving in a circle of radius r Let it start from A and reaches to B after time t , so that $\angle BOA = \theta$ (Fig. 2.9).

Now

$$\begin{aligned} \text{angle} &= \frac{\text{arc}}{\text{radius}} \\ \theta &= \frac{AB}{OA} = \frac{S}{r} \\ S &= r\theta \end{aligned}$$

Dividing both sides by time (t), we get

$$\frac{S}{t} = r \frac{\theta}{t}$$

Here $\frac{S}{t} = v$ is linear velocity

And $\frac{\theta}{t} = \omega$ is angular velocity

Hence $\boxed{v = r\omega}$

2.9 CENTRIPETAL AND CENTRIFUGAL FORCES

Centripetal Force: The force acting along the radius towards the centre of circle to keep a body moving with uniform speed in a circular path is called centripetal force. It is denoted by F_C .

$$F_C = \frac{mv^2}{r}$$

For example, a stone tied at one end of a string whose other end is held in hand, when round in the air, the centripetal force is supplied by the tension in the string.

Centrifugal Force:

A body moving in circle with uniform speed experience a force in a direction away from the centre of the circle. This force is called centrifugal force.

For example, cream is separated from milk by using centrifugal force. When milk is rotated in cream separator, cream particles in the milk being lighter, experience less centrifugal force.

2.10 APPLICATION OF CENTRIPETAL FORCE IN BANKING OF ROADS

Banking of Roads: While travelling on a road, you must have noticed that *the outer edge of circular road is slightly raised above as compared to the inner edge of road. This is called banking of roads (Fig. 2.10).*

Angle of Banking: The angle through which the outer edge of circular road is raised above the inner edge of circular roads is called angle of banking.

Application of centripetal force in banking of roads

- Let m = mass of vehicle
- r = radius of circular road
- v = uniform speed (velocity) of vehicle
- θ = angle of banking

At the body two forces act. Figure 2.10

- (i) Weight (mg) of vehicle vertically downwards.
- (ii) Normal reaction (R).

R makes an angle θ and resolves the forces into two components

- (i) $R \sin \theta$ towards the centre
- (ii) $R \cos \theta$ vertically upwards and balance by weight of (mg) vehicle

$R \sin \theta$ provides the necessary centripetal force ($\frac{mv^2}{r}$)

$$R \sin \theta = \frac{mv^2}{r} \quad \text{----- (1)}$$

and $R \cos \theta = mg \quad \text{----- (2)}$

Divide equation 1 by 2

$$\frac{R \sin \theta}{R \cos \theta} = \frac{\frac{mv^2}{r}}{mg}$$

$$\tan \theta = \frac{v^2}{rg}$$

$$\theta = \tan^{-1} \left(\frac{v^2}{rg} \right)$$

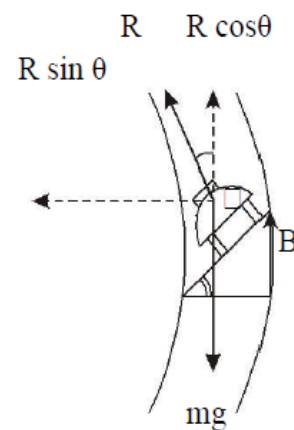

Figure: 2.10

EXERCISES

Fill in the blanks:

1. The maximum possible number of rectangular components of a vector is
2. The acceleration of the particle performing uniform circular motion is called.....
3. Centripetal force always acts (towards/away to) the centre of the circle.
4. Railway tracks are banked at the curves so that the necessaryforce may be obtained from the horizontal component of the reaction on the train.
5. The angle through which the outer edge of a circular road is raised above its inner edge is called
6. A model aeroplane fastened to a post by a fine thread is flying in a horizontal circle. Suddenly the thread breaks. The aeroplane will fly(inward/outward)
7. A force which acts for a small time and also varies with time is called

Short Answer Type Questions

1. State and explain laws of vector addition.
2. Explain resolution of a vector.
3. How is impulse related to linear momentum?
4. Define circular motion. Give examples.
5. Define banking of roads.
3. Define scalar and vector quantities with examples.
4. Define resolution and composition of forces.
5. Define impulse.
6. Why does a gun recoil when a bullet is fired?
7. Differentiate between centripetal and centrifugal forces.
8. An artificial satellite takes 90 minutes to complete its revolution around the earth. Calculate the angular speed of satellite. [Ans. 2700 rad/sec]
9. At what maximum speed a racing car can transverse an unbanked curve of 30 m radius? The co-efficient of friction between tyres and road is 0.6. [Ans. 47.8]
10. Define Force. Give its units.
11. Define Triangle law of vector addition.
12. State parallelogram law of vector addition.

Long Answer Type Questions

1. Explain Newton's Law of Motion.
2. Explain Banking of Roads.
3. State law of conservation of momentum.
4. Derive relationship between linear and angular velocity.
5. Derive a relation between linear acceleration and angular acceleration.

Chapter 3

WORK, POWER AND ENERGY

Learning objective: After going through this chapter, students will be able to;

- Understand work, energy and power, their units and dimensions.
- Describe different types of energies and energy conservation.
- Solve relevant numerical problems

3.1 WORK (DEFINITION, SYMBOL, FORMULA AND SI UNITS)

Work: is said to be done when the force applied on a body displaces it through certain distance in the direction of applied force.

$$\text{Work} = \text{Force} \times \text{Displacement}$$

In vector form, it is written as $\vec{F} \cdot \vec{S} = FS \cos\theta$

It is measured as the product of the magnitude of force and the distance covered by the body in the direction of the force. It is a scalar quantity.

Unit: SI unit of work is joule (J). In CGS system, unit of work is erg.

$$1\text{J} = 10^7 \text{ ergs}$$

$$\text{Dimension of work} = [\text{M}^1\text{L}^2\text{T}^{-2}]$$

Example1. What work is done in dragging a block 10 m horizontally when a 50 N force is applied by a rope making an angle of 30° with the ground?

Sol. Here, $F = 50 \text{ N}$, $S = 10 \text{ m}$, $\theta = 30^\circ$

$$W = FS \cos \theta$$

$$W = 50 \times 10 \times \cos 30^\circ$$

$$W = 50 \times 10 \times \frac{\sqrt{3}}{2}$$

$$= 612.4 \text{ J}$$

Example2. A man weighing 50 kg supports a body of 25 kg on head. What is the work done when he moves a distance of 20 m?

Sol. Total mass = $50 + 25 = 75 \text{ kg}$

$$\theta = 90^\circ$$

$$\text{Distance} = 20 \text{ m}$$

$$W = FS \times 0 \quad (\cos 90^\circ = 0)$$

$$W = 0$$

Thus, work done is zero.

Example3. A man weighing 50 kg carries a load of 10 kg on his head. Find the work done when he goes (i) 15 m vertically up (ii) 15 m on a levelled path on the ground.

Sol. Mass of the man, $m_1 = 50 \text{ kg}$

$$\text{Mass carried by a man, } m_2 = 10 \text{ kg}$$

$$\text{Total mass } M = m_1 + m_2 = 50 + 10 = 60 \text{ kg.}$$

When the man goes vertically up,

Height through which he rises, $h = 15 \text{ m}$

$$W = mgh = 60 \times 9.8 \times 15 = 8820 \text{ J}$$

When the man goes on a levelled path on the ground

$$W = FS \cos\theta$$

As $\theta = 90^\circ$, therefore, $\cos 90^\circ = 0$

$$\text{Hence } W = F \times S \times 0 = 0$$

3.2 ENERGY

Energy of a body is defined as *the capacity of the body to do the work*. Like work, energy is also a scalar quantity.

Unit: SI system – joule (J), CGS system - erg

Dimensional Formula: $[ML^2 T^{-2}]$.

Transformation of Energy

The phenomenon of changing energy from one form to another form is called transformation of energy. For example-

- In a heat engine, heat energy changes into mechanical energy
- In an electric bulb, the electric energy changes into light energy.
- In an electric heater, the electric energy changes into heat energy.
- In a fan, the electric energy changes into mechanical energy which rotates the fan.
- In the sun, mass changes into radiant energy.
- In an electric motor, the electric energy is converted into mechanical energy.
- In burning of coal, oil etc., chemical energy changes into heat and light energy.
- In a dam, potential energy of water changes into kinetic energy, then K.E rotates the turbine which produces the electric energy.
- In an electric bell, electric energy changes into sound energy.
- In a generator, mechanical energy is converted into the electric energy.

3.3 KINETIC ENERGY (FORMULA, EXAMPLES AND ITS DERIVATION)

Kinetic Energy (K.E.): the *energy possessed by the body by virtue of its motions* is called kinetic energy.

For example (i) running water (ii) Moving bullet.

Expression for Kinetic Energy

Consider F is the force acting on the body at rest (*i.e.*, $u = 0$), then it moves in the direction of force to distance (s).

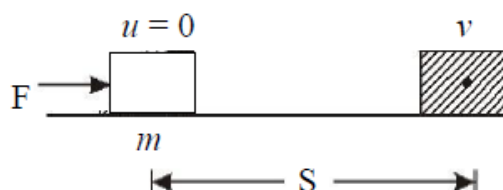

Figure: 3.1

Let v be the final velocity.

Using relation $v^2 - u^2 = 2aS$

$$\frac{v^2 - u^2}{2S} = a$$

$$\frac{v^2 - 0}{2S} = a$$

$$\frac{v^2}{2S} = a \quad \text{-----(1)}$$

Now, work done, $W = FS$

or $W = maS$ (using $F = ma$) ----- (2)

By equation (1) and (2)

$$W = m \cdot \frac{v^2}{2S} \cdot S$$

or $W = \frac{1}{2}mv^2$

This work done is stored in the body as kinetic energy. So kinetic energy possessed by the body is (K.E.) = $\frac{1}{2}mv^2$

3.4 POTENTIAL ENERGY

Potential Energy (P.E.): *the energy possessed by the body by virtue of its position is called potential energy.* Example

- (i) Water stored in a dam
- (ii) Mango hanging on the branch of a tree

Expression for Potential Energy (P.E)

It is defined as the energy possessed by the body by virtue of its position above the surface of earth.

$$\begin{aligned} W &= FS \\ \text{Work done} &= \text{Force} \times \text{height} \\ &= mg \times h = mgh \end{aligned}$$

This work done is stored in the form of gravitational potential energy. Hence Potential energy = mgh .

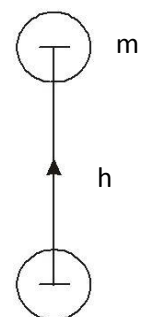

Figure: 3.2

LAW OF CONSERVATION OF ENERGY

Energy can neither be created nor be destroyed but can be converted from one form to another.

3.5 CONSERVATION OF MECHANICAL ENERGY OF A FREE FALLING BODY

Let us consider K.E., P.E. and total energy of a body of mass m falling freely under gravity from a height h from the surface of ground.

According to Fig. 3.3

At position A:

Initial velocity of body (u) = 0

$$\text{K.E} = \frac{1}{2}mv^2$$

$$\text{P. E.} = mgh$$

$$\text{Total Energy} = \text{K.E} + \text{P.E}$$

$$= 0 + mgh$$

$$= mgh$$

----- (1)

At position B

$$\text{Potential energy} = mg(h - x)$$

$$\text{Velocity at point B} = u$$

$$\text{From equation of motion K.E.} = \frac{1}{2}mu^2$$

$$\text{As } V^2 - U^2 = 2aS$$

$$\text{Hence } u^2 - 0^2 = 2gx$$

$$\text{or } u^2 = 2gx$$

$$\text{Putting this value we get, KE} = \frac{1}{2}m(2gx)$$

$$\text{or K.E.} = mgx$$

$$\text{Total Energy} = \text{K.E} + \text{P.E}$$

$$= mgx + mg(h - x)$$

$$= mgh$$

----- (2)

At position C

$$\text{Potential energy} = 0 \text{ (as } h = 0)$$

$$\text{Velocity at Point B} = v$$

$$\text{From equation of motion K.E.} = \frac{1}{2}mv^2$$

$$\text{As } V^2 - U^2 = 2aS$$

$$\text{Hence } v^2 - 0^2 = 2gh$$

$$\text{or } v^2 = 2gh$$

$$\text{Putting this value we get KE} = \frac{1}{2}m(2gh)$$

$$\text{or K.E.} = mgh$$

$$\text{Total Energy} = \text{K.E} + \text{P.E}$$

$$= mgh + 0$$

$$= mgh$$

----- (3)

From equations (1), (2) and (3), it is clear that total mechanical energy of freely falling body at all the positions is same and hence remains conserved.

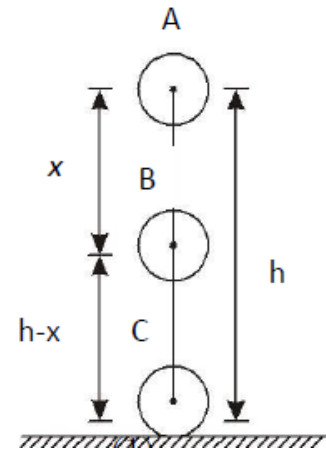

Figure: 3.3

Example 4 A spring extended by 20 mm possesses a P.E. of 10 J. What will be P.E., if the extension of spring becomes 30 mm?

Sol.

$$h = 20 \text{ mm} = 20 \times 10^{-3} \text{ m}$$

$$g = 9.8 \text{ ms}^{-2}, m = ?$$

$$\text{P.E} = mgh = 10 \text{ J}$$

i.e.,

$$m \times 9.8 \times 20 \times 10^{-3} = 10 \text{ J}$$

$$m = \frac{10}{9.8 \times 20 \times 10^{-3}}$$

$$m = 51.02 \text{ kg}$$

When extension is 30 mm *i.e.*, $30 \times 10^{-3} \text{ m}$, then

$$\begin{aligned} \text{P.E} &= mgh \\ &= 51.02 \times 9.8 \times 3 \times 10^{-3} = 15.0 \text{ J} \end{aligned}$$

3.6 POWER (DEFINITION, FORMULA AND UNITS)

Power is defined as the *rate at which work is done* by a force. *The work done per unit time* is also called power.

If a body do work W in time t , then power is $P = \frac{W}{t}$

Units of Power: SI unit of power is watt (W)

$$1\text{W} = \frac{1\text{J}}{1\text{s}}$$

Power is said to be 1 W, if 1 J work is done in 1 s.

Bigger units of power are:

kilowatt (kW)	= 10^3W
Megawatt (MW)	= 10^6 W
Horse power (hp)	= 746 W

$$\text{Dimension of power} = [\text{M}^1 \text{L}^2\text{T}^{-3}]$$

Example 5 A man weighing 65 kg lifts a mass of 45 kg to the top of a building 10 metres high in 12 second. Find;

(i) Total work done by him. The power developed by him.

Solution Mass of the man, $m_1 = 65 \text{ kg}$
 Mass lifted $m_2 = 45 \text{ kg}$
 Height through which raised $h = 10 \text{ m}$
 Time taken $t = 12 \text{ seconds}$.

(i) Total work done by the man, $W = mgh$

$$= 110 \times 9.81 \times 10 = 10791.0 \text{ J}$$

(ii) Power developed

$$P = \frac{W}{t} = \frac{10791\text{J}}{12\text{s}} = 899.25 \text{ W}$$

EXERCISES

Fill in the blanks:

1. There are two bodies X and Y with equal kinetic energy but different masses m and $4m$ respectively. The ratio of their linear momentum is.....
2. When a spring is stretched, its potential energy
3. $1 \text{ kWh} = \dots\dots \text{ J}$

Short Answer Type Questions

1. Define the terms energy, potential energy and kinetic energy.
2. Define potential energy, Derive expression for gravitational potential energy.
3. Define work and write its unit.
4. State and prove principle of conservation of energy.
5. Define power. Give it S.I unit and dimensions.
6. Explain transformation of energy.
7. A person walking on a horizontal road with a load on his head does not work. Explain.
8. Give some examples of transformation of energy.

Long Answer Type Questions

1. State and explain the law of conservation of energy for free falling body.
2. Define power and energy. Give their units.
3. Define kinetic energy with examples. Obtain an expression for kinetic energy of body moving with uniform speed.

Chapter 4

ROTATIONAL MOTION

Learning objective: After going through this chapter, students will be able to;

- Define rotational motion and parameters like; torque, angular momentum and momentum conservation.
- Describe Moment of inertia and radius of gyration.
- Solve relevant numerical problems.

4.1 ROTATIONAL MOTION WITH EXAMPLES

The rotation of a body about fixed axis is called Rotational motion. For example,

- Motion of a wheel about its axis
- Rotation of earth about its axis.

4.2 DEFINITION OF TORQUE AND ANGULAR MOMENTUM

Torque (τ)

It is measured as the product of magnitude of force and perpendicular distance of the line of action of force from the axis of rotation.

It is denoted by τ ,

$$\vec{\tau} = \vec{F} \times \vec{r}$$

Where F is external force and r is perpendicular distance.

Unit: newton (N)

Dimension Formula: $[M^1L^2T^{-2}]$

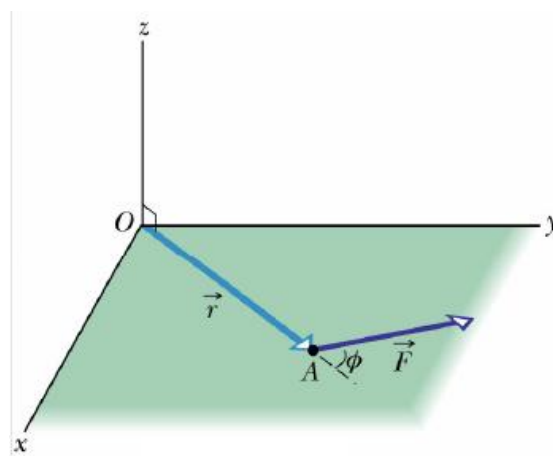

Figure: 4.1

Angular Momentum (L)

Angular momentum of a rotating body about its axis of rotation is the algebraic sum of the linear momentum of its particles about the axis. It is denoted by L. It is vector quantity.

$L = \text{momentum} \times \text{perpendicular distance}$

$$L = p \times r$$

or $L = mvr$

Unit: $\text{Kg m}^2/\text{sec}$

Dimensional Formula = $[ML^2T^{-1}]$

4.3 LAW OF CONSERVATION OF ANGULAR MOMENTUM

When no external torque acts on a system of particles, then the total angular momentum of the system always remains constant.

Let I be moment of inertia and ω the angular velocity, then angular momentum is given as

$$L = I\omega$$

Also the torque is given by

$$\tau = \frac{dL}{dt}$$

If no external torque acts on the body, then $\tau = 0$

$$\text{Hence } \tau = \frac{dL}{dt} = 0$$

Thus L is constant (as derivative of constant quantity is zero).

Hence, if no external torque acts on system, the total angular momentum remains conserved.

Examples:

- (i) An ice skater who brings in her arms while spinning spins faster. Her moment of inertia is dropping (reducing the moment of arm) so her angular velocity increases to keep the angular momentum constant
- (ii) Springboard diver stretches his body in between his journey.

5.4 MOMENT OF INERTIA AND ITS PHYSICAL SIGNIFICANCE

Moment of Inertia of a rotating body about an axis is defined as *the sum of the product of the mass of various particles constituting the body and square of respective perpendicular distance of different particles of the body from the axis of rotation.*

Expression for the Moment of Inertia:

Let us consider a rigid body of mass M having n number of particles revolving about any axis. Let $m_1, m_2, m_3, \dots, m_n$ be the masses of particles at distance $r_1, r_2, r_3, \dots, r_n$ from the axis of rotation respectively (Fig. 4.2).

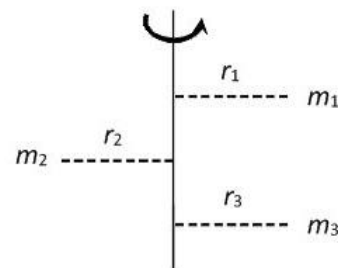

Figure: 4.2

Moment of Inertia of whole body

$$I = m_1 r_1^2 + m_2 r_2^2 + \dots + m_n r_n^2$$

$$\text{or } I = \sum_{i=1}^n m_i r_i^2$$

Physical Significance of Moment of Inertia

It is totally analogous to the concept of inertial mass. Moment of inertia plays the same role in rotational motion as that of mass in translational motion. In rotational motion, a body, which is free to rotate about a given axis, opposes any change in state of rotation. Moment of Inertia of a body depends on the distribution of mass in a body with respect to the axis of rotation.

Radius of Gyration (K)

It may be defined as *the distance of a point from the axis of rotation at which whole mass of the body is supposed to be concentrated, so that moment of inertia about the axis remains the same.* It is denoted by K

If the mass of the body is M , the moment of inertia (I) of the body in terms of radius of gyration is given as,

$$I = MK^2 \quad \text{----- (1)}$$

Expression for Radius of Gyration

Let $m_1, m_2, m_3 \dots, m_n$ be the masses of particles at distance $r_1, r_2, r_3 \dots r_n$ from the axis of rotation respectively (Fig. 4.3).

Then Moment of Inertia of whole body

$$I = m_1 r_1^2 + m_2 r_2^2 + \dots + m_n r_n^2$$

If mass of all particles is taken same, then

$$I = m (r_1^2 + r_2^2 + \dots + r_n^2)$$

Multiply and divide the equation by n (number of particle)

$$\Rightarrow I = \frac{m \times n (r_1^2 + r_2^2 + \dots + r_n^2)}{n}$$

$$\text{or } I = \frac{M (r_1^2 + r_2^2 + \dots + r_n^2)}{n} \quad \text{----- (2)}$$

($M = m \times n$, is total mass of body)

Comparing equation (1) and (2), we get

$$MK^2 = \frac{M (r_1^2 + r_2^2 + \dots + r_n^2)}{n}$$

$$\text{Or } K^2 = \frac{(r_1^2 + r_2^2 + \dots + r_n^2)}{n}$$

$$K = \sqrt{\frac{(r_1^2 + r_2^2 + \dots + r_n^2)}{n}}$$

Thus, radius of gyration may also be defined as the root mean square (r.m.s.) distance of particles from the axis of rotation.

Unit: metre.

Example 1. What torque will produce an acceleration of 2 rad/s^2 in a body if moment of inertia is 500 kg m^2 ?

Sol. Here, $I = 500 \text{ kg m}^2$

$$\alpha = 2 \text{ rad/s}^2$$

Now, torque $\tau = I \times \alpha$

$$= 500 \text{ kgm}^2 \times 2 \text{ rad/s}^2 = 1000 \text{ kg m}^2 \text{s}^{-2}$$

$$= 1000 \text{ Nm or J}$$

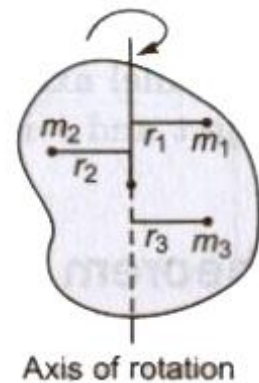

Figure: 4.3

Example 2. An engine is rotating at the rate of 1500 rev. per minute. Find its angular velocity.

Sol. Here, Revolution per minute of engine, $n = 1500$

$$\text{Angular velocity } \omega = 2\pi n$$

$$\text{Or } \omega = 2 \times \frac{22}{7} \times \frac{1500}{60}$$

$$\omega = 157.1 \text{ rad/s}$$

Example 3. How large a torque is needed to accelerate a wheel, for which $I = 2 \text{ kgm}^2$, from rest to 30 r.p.s in 20 seconds?

Sol. Here, Moment of inertia, $I = 2 \text{ kgm}^2$

$$\text{R.P.S after 20 sec, } n = 30$$

$$\text{Initial velocity, } \omega_1 = 0$$

$$\text{Final velocity, } \omega_2 = 2 \times \pi \times 30 = 188.4 \text{ rad/s.}$$

$$\text{Angular acceleration} = \frac{\omega_2 - \omega_1}{t} = \frac{188.4 - 0}{20} = 9.43 \text{ rad/s}^2.$$

$$\begin{aligned} \text{Now, torque, } \tau &= I \times \alpha \\ &= 2 \text{ kg m}^2 \times 9.43 \text{ rad/s}^2 \\ &= 18.86 \text{ Nm or J} \end{aligned}$$

Example 4. If a point on the rim of wheel 4 m in diameter has a linear velocity of 16 m/ s, find the angular velocity of wheel in rad/sec.

$$\text{Sol. Radius of wheel (R)} = \frac{\text{Diameter}}{2} = \frac{4}{2} = 2 \text{ m}$$

$$\text{From the relation } v = r\omega$$

$$\omega = \frac{v}{r} = \frac{16}{2} = 8 \text{ rad/s.}$$

Angular velocity of wheel is 8 rad/s.

EXERCISES

Fill in the blanks:

1. The radius of gyration of a ring of radius R about an axis through its centre and perpendicular to its plane is
2. Two rings have their moment of inertia in the ratio 2:1 and their diameters are in the ratio 2:1. The ratio of their masses will be
3. A person standing on a rotating platform with his hands lowered outstretches his arms. The angular momentum of the person
4. An earth satellite is moving around the earth in a circular orbit. In such a case, is conserved.
5. When no external torque acts on a system, its is conserved.

Short Answer Type Question

1. Define torque.
2. Define rotational inertia or moment of inertia. Give its SI unit.
3. Define radius of gyration and give its SI units.
4. Derive the relation between torque and angular momentum.

Long Answer Type Question

1. Derive an expression for angular momentum in terms of moment of inertia.
2. State and prove law of conservation of angular momentum.
3. Define radius of gyration and derive its expression.
4. Define moment of inertia. Derive its expression and explain its physical significance.

Chapter 5

PROPERTIES OF MATTER

Learning objective: After going through this chapter, students will be able to;

- Understand elasticity, deforming force, restoring force etc.
- Define stress, strain, Hook's law, modulus of elasticity, pressure etc..
- Describe surface tension, viscosity and effect of temperature on these.
- Understand fluid motion and nature of flow.

5.1 DEFINITION OF ELASTICITY, DEFORMING FORCE, RESTORING FORCE, EXAMPLE OF ELASTIC AND PLASTIC BODY

Elasticity: It is the property of solid materials to return to their original shape and size after removal of deforming force.

Deforming Forces: The forces which bring the change in configuration of the body are called deforming forces.

Restoring Force: It is a force exerted on a body or a system that tends to move it towards an equilibrium state.

Elastic Body: It is the body that returns to its original shape after a deformation. Examples are Golf ball, Soccer ball, Rubber band etc.

Plastic Body: It is the body that do not return to its original shape after a deformation. Examples are Polyethylene, Polypropylene, Polystyrene and Polyvinyl Chloride (PVC).

5.2 DEFINITION OF STRESS AND STRAIN WITH THEIR TYPES

Stress: It is defined as *the restoring force per unit area* of a material. Stress is of two types:

1. **Normal Stress:** If deforming force acts normal (perpendicular) to the surface of the body then the stress is normal stress.
2. **Tangential Stress:** If deforming force acts tangentially to the surface of the body then the stress is tangential stress.

Strain: It is defined as *the ratio of change in configuration to the original configuration*, when a deforming force is applied to a body. The strain is of three types:

(i) Longitudinal strain:

If the deforming force produces a change in length only, the strain produced is called longitudinal strain or tensile strain. It is defined as *the ratio of change in length to the original length*.

$$\text{Longitudinal strain} = \frac{\text{Change in length}(\Delta l)}{\text{original length}(l)}$$

(ii) **Volumetric strain:** It is defined as *the ratio of the change in volume to the original volume*.

$$\text{Volumetric strain} = \frac{\text{Change in volume}(\Delta V)}{\text{original volume}(V)}$$

(iii) **Shearing strain:**

It is defined as *the ratio of lateral displacement of a surface under the tangential force to the perpendicular distance between surfaces*

$$\begin{aligned} \text{Shearing strain} &= \frac{\text{Lateral Displacement}}{\text{Distance between surfaces}} \\ &= \frac{\Delta L}{L} = \tan \phi \end{aligned}$$

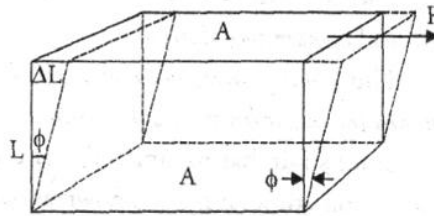

Figure: 5.1

The shearing strain is also defined as the angle in radian through which a plane perpendicular to the fixed surface of a rectangular block gets turned under the effect of tangential force.

Units of strain:

Strain is a ratio of two similar physical quantities, it is unitless and dimensionless.

5.3 HOOK'S LAW, MODULUS OF ELASTICITY

Hook's law: *Within elastic limits, the stress and strain are proportional to each other.*

Thus, Stress \propto Strain

$$\text{Stress} = E \times \text{Strain}$$

Where E is the proportionality constant and is known as modulus of elasticity.

Modulus of Elasticity: *The ratio of stress and strain is always constant and called as modulus of elasticity.*

Young's Modulus (Y): *The ratio of normal stress to the longitudinal strain is defined as Young's modulus and is denoted by the symbol Y.*

$$Y = \frac{F/A}{\Delta l/l} = \frac{F \times l}{A \times \Delta l}$$

The unit of Young's modulus is the same as that of stress i.e., Nm^{-2} or pascal (Pa)

Bulk Modulus (K): *The ratio of normal (hydraulic) stress to the volumetric strain is called bulk modulus. It is denoted by symbol K.*

$$K = \frac{F/A}{\Delta V/V} = \frac{F \times V}{A \times \Delta V}$$

SI unit of bulk modulus is the same as that of pressure i.e., Nm^{-2} or Pa

Shear Modulus or Modulus of rigidity (η): *The ratio of shearing stress to the corresponding shearing strain* is called the shear modulus of the material and is represented by η . It is also called the modulus of rigidity.

$$\eta = \frac{\text{Tangential stress}}{\text{Shear strain}}$$

$$\eta = \frac{F/A}{\Delta L/L} = \frac{F \times L}{A \times \Delta L}$$

The SI unit of shear modulus is Nm^{-2} or Pa.

5.4 PRESSURE

Pressure: *It is defined as the force acting per unit area over the surface of a body.*

$$P = \frac{F}{A}$$

SI unit is Nm^{-2} or Pa

Pascal Law: *A change in the pressure applied to an enclosed incompressible fluid is transmitted undiminished to every portion of the fluid and to the walls of its container.*

Or it states that liquid enclosed in a vessel exerts equal pressure in all the directions.

5.5 SURFACE TENSION

The property of a liquid due to which its free surface behaves like stretched membrane and acquires minimum surface area. It is given by force per unit length.

$$T = \frac{F}{l}$$

Surface tension allows insects (usually denser than water) to float and stride on a water surface.

SI unit is N/m.

Applications of surface tension in daily life

It plays an important role in many applications in our daily life.

- Washing clothes
- Cleaning
- Cosmetics
- Lubricants in machines
- Spreading of ink, colours
- Wetting of a surface
- Action of surfactants
- Paints, insecticides
- Creating fuel-spray in automobile engines
- Passing of liquid in porous media
- Spherical shape of water droplets.

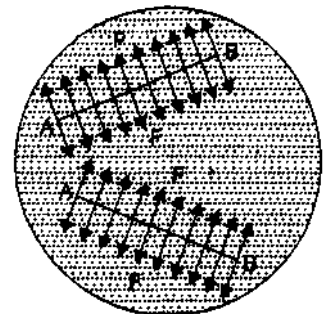

Figure: 5.2

Effect of Temperature on Surface Tension

In general, *surface tension decreases* when *temperature increases* and vice versa. This is because cohesive forces decrease with an increase of molecular thermal activity. The influence of the surrounding environment is due to the adhesive action liquid molecules have at the interface.

5.6 VISCOSITY

The property of liquid due to which it oppose the relative motion between its layers. It is also known as liquid friction.

SI unit of viscosity is pascal-second (Pas) and cgs unit is poise.

Effect of Temperature on Viscosity

In liquids the source for viscosity is considered to be atomic bonding. As we understand that, with the increase of temperature the bonds break and make the molecule free to move. So, we can conclude that the *viscosity decreases as the temperature increases and vice versa*.

In gases, due to the lack of cohesion, the source of viscosity is the collision of molecules. Here, *as the temperature increases the viscosity increases and vice versa*. This is because the gas molecules utilize the given thermal energy in increasing its kinetic energy that makes them random and therefore resulting in more the number of collisions.

5.7 FLUID MOTION, STREAM LINE AND TURBULENT FLOW

Fluid Motion: A liquid in motion is called fluid. There are two types of fluid motions; streamline and turbulent.

Streamline Flow: Flow of a fluid in which its velocity at any point of given cross section is same. It is also called laminar flow.

Turbulent flow: It is type of fluid (gas or liquid) flow in which the speed of the fluid at given cross section is continuously undergoing changes in both magnitude and direction.

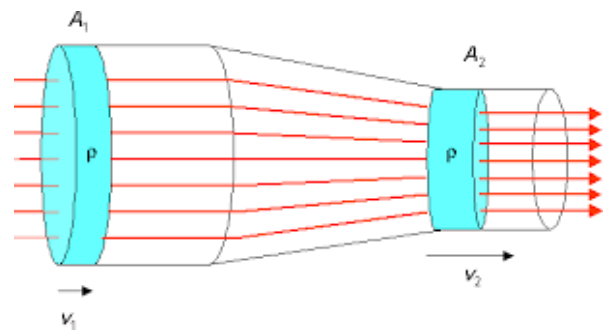

Figure: 5.3

EXERCISES

Fill in the blanks

- 1) Stress is defined as the per unit area of a material.
- 2) is the ratio of change in dimensions to the original dimensions.
- 3) For small deformations the stress and strain are proportional to each other. This is called
- 4) Pressure is defined as the force per unit over the surface of a body.
- 5) A change in the pressure applied to an enclosed incompressible fluid is transmitted undiminished to every portion of the fluid to the walls of its container. It is called.....
- 6) The property of solid materials to return to their original shape and size after the removal of deforming forces is called

Short Answer Type Questions

1. Define elasticity.
2. Define viscosity.
3. Define turbulent flow.
4. Define surface tension.
5. What is Young's modulus of elasticity?
6. State and explain Hooks Law.
7. State and explain Pascal's Law.
8. What is the effect of temperature on surface tension?
9. What is the effect of temperature on viscosity?
10. Give any five applications of surface tension.
11. Write difference between elastic and plastic bodies.

Long Answer Type Questions

1. Explain different kind of modulus of elasticity.
2. Define surface tension. Give formula, units and applications of surface tension.
3. Explain streamline flow, laminar flow and turbulent flow.
4. Explain different types of stress.
5. Explain Young's modulus of elasticity and its units.

Chapter 6

HEAT AND TEMPERATURE

Learning Objectives: After going through this chapter, the students will be able to:

- Define heat and temperature; understand the difference between heat and temperature;
- Describe principles of measuring temperature and different temperature scales,
- Enlist properties of heat radiations and various modes of transfer of heat.

6.1 HEAT AND TEMPERATURE

All objects are made of atoms or molecules. These molecules are always in some form of motion (linear, vibrational or rotational) and possess kinetic energy by virtue of their motion. The hotter an object is, faster will be the motion of the molecules inside it and hence more will be its kinetic energy. Heat of an object is the total energy of all the individual molecules of which the given object is made. It is a form of thermal energy. When the object is heated, its thermal energy increases, means its molecules begin to move more violently. Temperature, on the other hand, is a measure of the average heat or thermal energy of the molecules in a substance.

Heat is the form of energy which produces the sensation of warmth or coldness.

The cgs unit of heat is the calorie (cal) - defined as the amount of heat required to raise the temperature of 1g of water through 1°C. The S.I. unit of heat energy is the joule (J) The relation between these two units is:

$$1 \text{ cal} = 4.18 \text{ J.}$$

Heat on the basis of kinetic theory: According to the kinetic theory, heat of a body is total kinetic energy of all its molecules. If a body have 'n' number of molecule having mass *m* and velocities $v_1, v_2, v_3, \dots, v_n$ respectively, then

Total heat energy in the body (H) = Sum of kinetic energy of all molecules

$$H = K \left(\frac{1}{2}mv_1^2 + \frac{1}{2}mv_2^2 + \frac{1}{2}mv_3^2 + \dots + \frac{1}{2}mv_n^2 \right) \quad ; \text{ where K is thermal constant.}$$

When the body is heated, the kinetic energy of each molecule inside it increases due to increase in their velocity. This results in the increase of total kinetic energy of the body and in turn represents total heat of the body.

Temperature

Temperature is the degree of hotness or coldness of the body. It is the average kinetic energy of all the molecules of which the given body is made and is given by the expression;

$$T = \frac{K \left(\frac{1}{2}mv_1^2 + \frac{1}{2}mv_2^2 + \frac{1}{2}mv_3^2 + \dots + \frac{1}{2}mv_n^2 \right)}{n}$$

Units of temperature are; fahrenheit (°F), celsius (°C) and kelvin (K). Kelvin is the S.I. unit of temperature.

6.2 DIFFERENCE BETWEEN HEAT AND TEMPERATURE:

Heat	Temperature
Heat is energy that is transferred from one body to another as the result of a difference in temperature	Temperature is a measure of degree of hotness or coldness
It is total kinetic energy of all the molecules	It is average kinetic energy of all the molecules
It depends on quantity of matter	It does not depend on quantity of matter
It is form of energy (Thermal)	It is measure of energy
S.I. unit is joule	S.I. unit is kelvin

6.3 PRINCIPLES OF MEASUREMENT OF TEMPERATURE:

Measurement of temperature depends on the principle that *properties (physical/ electrical/ chemical) of material changes with change in temperature*. A device that utilizes a change in property of matter to measure temperature is known as thermometer. Temperature is a principle parameter that needs to be monitored and controlled in most engineering applications such as heating, cooling, drying and storage. Temperature can be measured via a diverse array of sensors. All of them infer temperature by sensing some change in a physical characteristic; be it a thermal expansion, thermoelectricity, electrical resistance or thermal radiation. There are four basic types of thermometers, each working on a different principle:

1. Mechanical (liquid-in-glass, bimetallic strips, bulb & capillary, pressure type etc.)
2. Thermo-electric (Thermocouples)
3. Thermo-resistive (RTDs and thermistors)
4. Radiative (Infrared and optical pyrometers).

Each produces a different scale of temperature which can be related to one another. Commonly used thermometers are mercury thermometer, platinum resistance thermometer, thermo-electric and pyrometers. Liquid thermometers can measure temperature upto 300°C. Resistance thermometers can go upto 1200°C while thermo-electrics are used for measuring temperature as high as 3000°C. For still higher temperatures pyrometers (very hot furnaces) are used.

6.4 DIFFERENT SCALES OF TEMPERATURE AND THEIR RELATIONSHIP

In general, there are three scales of temperature measurement. The scales are usually defined by two fixed points; temperature at which water freezes and the boiling point of water as defined at sea level and standard atmospheric pressure.

a) Fahrenheit Scale: It was given by physicist Daniel Gabriel Fahrenheit in 1724. It uses the degree fahrenheit (symbol: °F) as the unit. On this scale, freezing point of water is taken as the lower fixed point (32°F) and boiling point of water is taken as upper fixed point (212°F). The interval between two points is divided into 180 equal parts. Each division is 1° F.

This scale is used for clinical and meteorological purpose.

b). Celsius Scale: This scale was given by Anders Celsius in 1742. On this scale, freezing point of water is taken as the lower fixed point (marked 0°C) and boiling point of water is taken as upper fixed point (marked 100°C). The interval between two points is divided into 100 equal parts. Each division is 1°C .

This scale is used for common scientific, clinical, meteorological and technological work.

c). Kelvin Scale: This scale defines the SI base unit of temperature with symbol K. On this scale freezing point of water is taken as the lower fixed point (273K) and boiling point of water is taken as upper fixed point (373K). The interval between two points is divided into 100 equal parts. Each division is 1K.

On scale $1^{\circ}\text{C} = 1\text{ K}$

This is the natural scale of temperature also called the *absolute temperature scale*. The scale is based on ideal gas thermometer.

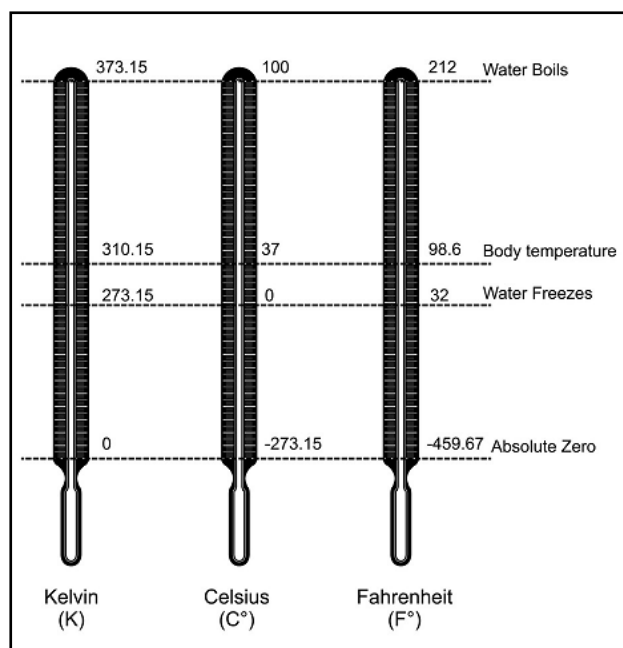

Figure 6.1 Temperature scales

Absolute Zero: Absolute zero is the temperature at which all molecular motions come to stand still i.e. net kinetic energy becomes zero. It is taken as zero kelvin (-273°C). At absolute zero temperature, the pressure (or volume) of the gas goes to zero. This may imply that if the temperature is reduced below -273.15°C , the volume becomes negative which is obviously not possible. Hence -273.15°C is the lowest temperature that can be achieved and therefore called the absolute zero of temperature. The interval on the scale is the same as on the Celsius scale ($1\text{ K} = 1^{\circ}\text{C}$) and two scales can be related as.

$$\text{K} = ^{\circ}\text{C} + 273.15$$

Thus on absolute scale of temperature, water freezes at 273.15K and boils at 373.15K.

Triple Point of water: The triple point is that point on a pressure versus temperature graph which corresponds to the equilibrium among three phases of a substance i.e. gas, liquid and solid.

Triple point of pure water is at 273.16K. It is unique and occurs at single temperature and single pressure.

RELATION AMONG THE SCALES OF TEMPERATURE

Temperature of a body can be converted from one scale to the other.

Let, L = lower reference point (freezing point)

H = upper reference point (boiling point)

T = temperature read on the given scale.

Now $\frac{T - L}{H - L} = \text{Relative temperature w.r.t. both reference point.}$

Let us take a body whose temperature is determined by three different thermometers giving readings in °C, °F and K respectively.

Let $T_1 = C = \text{Temperature in } ^\circ\text{C}, \quad L_1 = 0^\circ\text{C} \quad H_1 = 100^\circ\text{C}$
 $T_2 = F = \text{Temperature in } ^\circ\text{F}, \quad L_2 = 32^\circ\text{F} \quad H_2 = 212^\circ\text{F}$
 $T_3 = K = \text{Temperature Kelvin}, \quad L_3 = 273 \text{ K} \quad H_3 = 373\text{K}$

We can write,

$$\left(\frac{T_1 - L_1}{H_1 - L_1}\right) = \left(\frac{T_2 - L_2}{H_2 - L_2}\right) = \left(\frac{T_3 - L_3}{H_3 - L_3}\right)$$

$$\left(\frac{C - 0}{100 - 0}\right) = \left(\frac{F - 32}{212 - 32}\right) = \left(\frac{K - 273}{373 - 273}\right)$$

$$\frac{C}{100} = \frac{F - 32}{180} = \frac{K - 273}{100}$$

$\frac{C}{5} = \frac{F - 32}{9} = \frac{K - 273}{5}$
--

6.5 MODES OF TRANSFER OF HEAT

When two bodies having different temperatures are brought close together, the heat flows from body at higher temperature to body at lower temperature. Heat may also flow from one portion of body to another portion because of temperature difference. The process is called transfer of heat. There are three modes by which heat is transferred from one place to another. These are named as conduction, convection and radiations.

(i) Conduction: It is defined as that mode of transfer of heat in which *the heat travels from particle to particle* in contact, along the direction of fall of temperature *without any net displacement of the particles.*

For example, if one end of a long metal rod (iron or brass) is heated, after some time other end of rod also become hot. This is due to the transfer of heat energy from hot atoms to the nearby atoms. When two bodies have different temperatures and are brought into contact, they exchange heat energy and tend to equalize the temperature. The bodies are said to be in *thermal equilibrium*. This is the mode of heat transfer in solids.

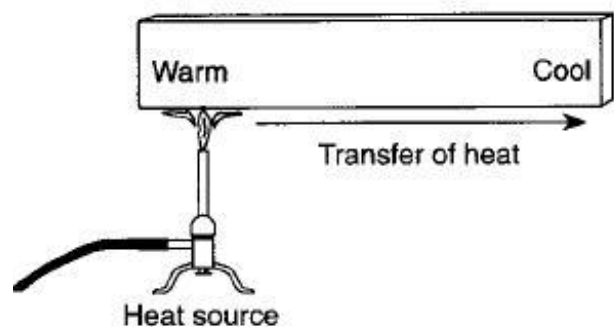

Figure 6.2: Conduction

ii) Convection: The process of transmission of heat in which *heat is transferred from one point to another by the physical movement of the heated particles* is called convection.

For example, if a liquid in a vessel is heated by placing a burner below the vessel, after some time the top surface of liquid also become warm. This is because the speed of atoms or molecules increases when liquid or gases are heated. The molecule having more kinetic energy rise upward and carry heat with them. Liquids and gases transfer heat by convection. Examples are heating of water, cooling of transformers, see breeze, heating of rooms by heater etc.

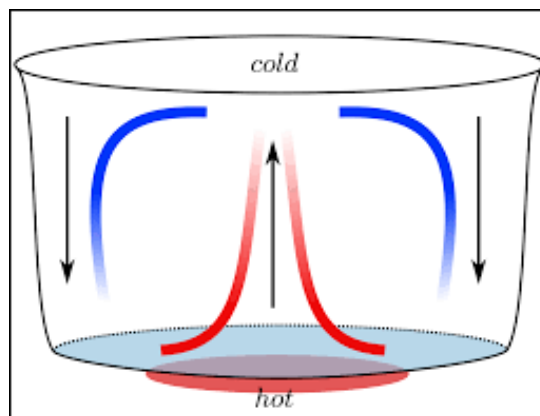

Figure 6.3: Convection

(iii) Radiation: The process of heat transfer in which *heat is transmitted from one place to another in the form of Infra-Red radiation, without heating the intervening medium is called radiation.*

Thermal radiations are the energy emitted by a body in the form of radiations on account of its temperature and travel with the velocity of light. We receive heat from sun by radiation process. All the bodies around us do emit these radiations. These radiations are the electromagnetic waves.

6.6 PROPERTIES OF HEAT RADIATIONS

1. They do not require a medium for their propagation.
2. Heat radiations travel in straight line.
3. Heat radiations do not heat the intervening medium.
4. Heat radiations are electromagnetic waves.
5. They travel with a velocity 3×10^8 m/s in vacuum.
6. They undergo reflection, refraction, interference, diffraction and polarization.
7. They obey inverse square law.

* * * * *

EXERCISES

Fill in the blanks and true/false

- i. Heat of an object is the (total/average) energy of all the molecular motions inside that object.
- ii. Temperature is a measure of the energy of the molecules.
- iii. Transfer of heat from a fluid to a solid surface or within a fluid is called
- iv. Matter that is at finite temperature emits energy in space in the form of electromagnetic waves. The process is known as
- v. Heat radiation travels at the same speed as sound. (True/ False).
- vi. The Kelvin scale is an absolute scale. (True/ False)
- vii. Heat radiations cannot travel through a vacuum. (True / False)
- viii. Air conditioner is an example of radiation. (True / False)

Short Answer Questions

1. Define heat. Give SI unit of heat.
2. Define temperature. Give SI unit of temperature.
3. What are heat radiations? Whether these travel in straight line or not?
4. What is principle of measurement of temperature?
5. Define absolute zero temperature.
6. What is triple point?
7. Give two examples of convection.
8. Define the process of conduction in metals.
9. Give relationship between celsius and fahrenheit scales of temperature.
10. Temperature of a patient is 40°C . What will be the corresponding temperature on Fahrenheit scale?

Long Answer Questions

- 1) Explain heat and temperature on basis of kinetic theory.
- 2) Describe principle of temperature measurements and name two such devices.
- 3) Describe with example different modes of transfer of heat.
- 4) Explain different scales of temperature and establish relationship between them.
- 5) Give any five properties of heat radiations.

Chapter 7

WAVE MOTION AND ITS APPLICATIONS

Learning Objective: After going through this chapter, students will be able to;

- *Understand concept of waves and wave motion, define parameters representing a wave motion and their relationship, define simple harmonic motion with examples, understand vibrations and types of vibrations.*
- *Describe concept of acoustics, associated parameters and methods to control acoustics of buildings.*
- *Identify ultrasonic waves and enlist their engineering applications.*

7.1 WAVE MOTION

Motion of an object is the change in its position with time. In different types of motions, some form of energy is transported from one place to another. There are two ways of transportation of energy from its place of origin to the place where it is to be utilized. One is the actual transport of matter. For example when a bullet is fired from a gun it carries kinetic energy which can be utilized at another place. The second method by which energy can be transported is the wave process.

A wave is the disturbance in which energy is transferred from one point to other due to repeated periodic motion of particles of the medium. The waves carry energy but there is no transport of matter.

There are two types of waves;

1. Mechanical or Elastic waves
2. Electromagnetic waves

Mechanical waves

Those waves which are produced due to repeated periodic motion of medium particles are called mechanical or elastic waves. They need a material medium for their generation and propagation.

For example sound waves, water waves are mechanical in nature.

Electromagnetic waves

The wave which travels in form of varying electric and magnetic fields mutually perpendicular to each other and also perpendicular to direction of propagation of wave. They do not need material medium for their propagation.

For example, light waves, heat radiations, radio waves, X-rays are electromagnetic waves.

The characteristics of wave motion are:

1. The wave travels forward but the particles vibrate only about their mean position.
2. The velocity of wave is the rate at which the disturbance travels through the medium.
3. The velocity of the wave depends on the type of wave (light, sound) and type of medium (solid, liquid or gas).
4. The velocity of waves is different from the velocity of particles.
5. There is regular phase difference between particles of wave.

Types of Wave Motion: There are two types of wave motion;

- a) Transverse wave motion
- b) Longitudinal wave motion

a) Transverse wave motion

When the particles of the medium vibrate *perpendicular to the direction of propagation* of wave the wave motion is called transverse wave motion. A transverse wave motion is shown in Fig. 7.1. A transverse wave consists of one crest and one trough that makes one cycle. The distance between two consecutive crests or two consecutive troughs is called wave length.

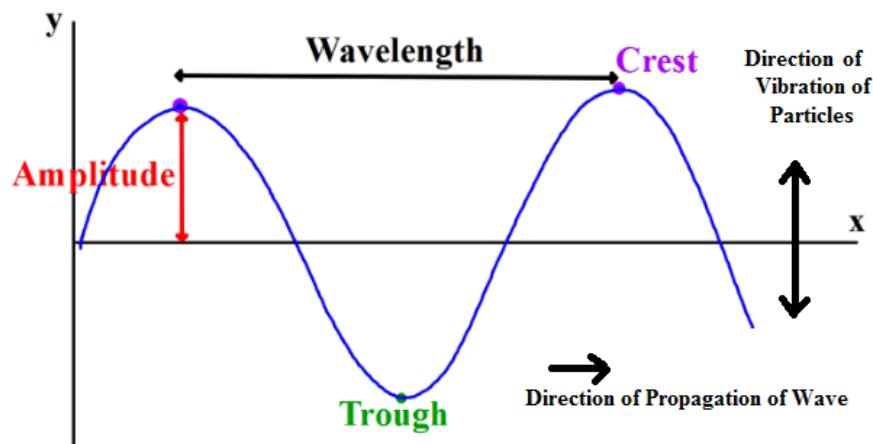

Fig. 7.1

Examples are wave produced by a stretched string, light waves, waves produced on surface of water etc.

b) Longitudinal Waves

When the particles of medium vibrate parallel to the direction of propagation of wave the wave motion is called longitudinal wave motion. A longitudinal wave travels in the form of compressions and rarefactions as shown in the Fig. 7.2. The part of medium where distance between medium particles is less than their normal distance is called compression and the portion where distance is more than their normal distance is called rarefaction. One cycle consist of one complete compression and one complete rarefaction. The distance between two consecutive compressions and rarefaction is called wave length.

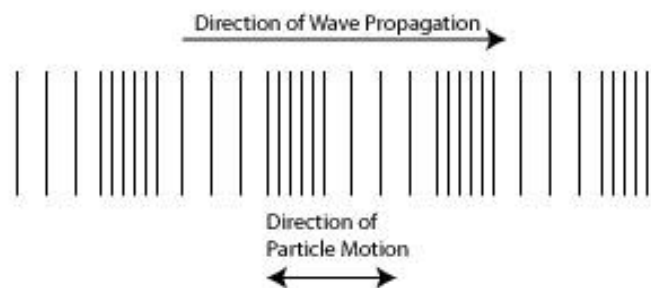

Fig. 7.2

Most familiar example of longitudinal waves is sound waves. Sound waves can travel in different medium such as solids, liquids and gases.

The main points of difference between transverse and longitudinal waves are listed below:

S. No.	Transverse Waves	Longitudinal Waves
1.	The particles of the medium vibrate perpendicular to the direction of propagation of wave	The particles of medium vibrate parallel to the direction of propagation of wave
2.	The wave travels in form of crests and troughs	The wave travels in form of compressions and rarefactions.
3.	There is no change in density of the medium.	These waves produce change in density of the medium.
4.	These waves can be polarised.	These waves cannot be polarised.
5.	Velocity of wave decreases with density of medium	Velocity of wave increases with density of medium
6.	Electromagnetic waves, wave travelling on stretched string, light waves are the examples.	Sound waves, pressure waves, musical waves are its examples.

Terms Characterizing Wave Motion:

Various parameters used to characterize a wave motion are defined below.

Displacement: The distance of a particle from its mean position, at any instant is called displacement.

Amplitude: It is the maximum displacement of the particle from its mean position of rest.

Wavelength: It is the distance travelled by the wave in the time in which the particle of the medium completes one vibration.

Or the distance between two consecutive crests or troughs is called as wavelength.

It is denoted by λ and measured in metres. The distance AB or DE in figure 7.3 is equal to one wave length.

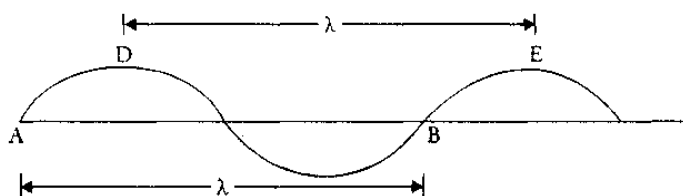

Fig. 7.3

Time period: It is defined as the time taken by a wave to complete one vibration or one cycle. It is denoted by T and SI unit is second.

Frequency: The number of vibrations made by a wave in one second is called frequency. It can also be written as reciprocal of time period ($\nu = 1/T$).

It is represented by n or ν (nu) and units are hertz (Hz), kilohertz (kHz), Megahertz (MHz) ... etc.

Wave Velocity: *The distance travelled by the wave per unit time is defined as wave velocity. It is denoted as (v) and measured in m/s.*

Or it may be defined as the velocity by which a wave propagates is called as wave velocity.

Phase: *Phase of a vibrating particle tells the position of a particle at that instant. It is measured by the fraction of angle or time elapsed by wave at any instant since the particle has crossed its mean position in positive direction. It is denoted by θ and unit is radian.*

Phase difference: *The difference in angle or time elapsed between two particles at any instant. It is calculated by the formula*

$$\text{Phase difference } (\phi) = \frac{2\pi}{\lambda} \times \text{path difference}$$

Relation between Wave velocity, Wavelength and Frequency

Wave velocity is the distance travelled by a wave in one time period.

$$v = \frac{\text{distance}}{\text{time}} = \frac{\lambda}{T}$$

and frequency is reciprocal of time period i.e.

$$v = \frac{1}{T}$$

$$\text{Thus } v = \nu \lambda$$

The relation holds for both transverse and longitudinal waves.

Numerical 1: A radio station broadcasts at a frequency of 15 MHz. The velocity of transmitted waves is 3×10^8 m/s. What is the wavelength of transmitted waves?

Solution: Given, frequency (ν) = 15 MHz = 15×10^6 Hz,

Velocity of waves (v) = 3×10^8 m/s

Using relation; $v = \nu \lambda$

$$\text{we get wavelength } (\lambda) = \frac{v}{\nu} = \frac{3 \times 10^8}{15 \times 10^6} = 20 \text{ m}$$

Numerical 2: A tuning fork of frequency 512 Hz makes 24 vibrations in air. If velocity of sound in air is 340 m/s, how far does sound travel in air?

Solution: Here, frequency (ν) = 512 Hz and velocity = 340 m/s

Using the relation $v = \nu \lambda$, we get

$$\text{Wavelength } (\lambda) = \frac{V}{\nu} = \frac{340}{512} = 0.664 \text{ m}$$

Therefore, distance in 24 vibrations = $24 \times \lambda = 24 \times 0.664 \text{ m} = 15.94 \text{ m}$

7.2 FREE, FORCED AND RESONANT VIBRATIONS

Vibrations

A motion in which the object moves to and fro about a fixed mean position is called oscillatory motion (vibration). All oscillatory motion needs to be periodic. The motion in which the object repeats its path after a fixed or regular interval of time is called periodic motion. For example, motion of hands of clock, motion of spring mass system, simple pendulum, cantilever, rim of cycle wheel etc.

Types of Vibrations: There are three types of vibrations: free, forced and resonant.

1) **Free Vibrations:** A force can set a resting object into motion. But when the force is a short-lived or momentary, it only begins the motion. The object moves back and forth, repeating the motion over and again.

When a body is set into vibrations and is allowed to vibrate freely under the influence of its own elastic forces, such vibrations are called free vibrations.

The frequency of free vibration is called natural frequency. Examples are vibrations of simple pendulum, cantilever, loaded beam etc.

Free vibrations can also be divided in two classes; damped and undamped vibrations.

a) Damped Vibrations:

In case of free vibrations, the extent of displacement from the equilibrium position reduces with time. This is because the force that started the motion is a momentary force and the vibrations ultimately cease. The object is said to experience damping. Thus *when the amplitude of vibrations goes on decreasing with time and finally the vibrations stop after some time then such vibrations are called damped vibrations* as shown in Fig.7.4. For example vibrations of cantilever, loaded beam, spring mass system etc. Damping is the tendency of a vibrating object to lose or to dissipate its energy over time.

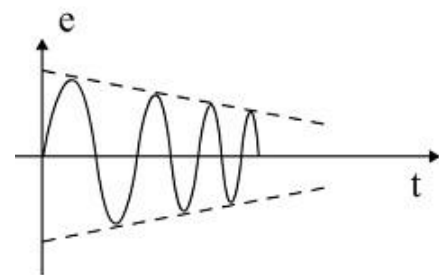

Fig. 7.4. Damped vibrations

b) Undamped Vibrations:

If the amplitude of vibrations remains constant and the vibrations continue for infinite time then such vibrations are called undamped vibrations as shown in Fig. 7.5. For example vibrations of simple pendulum in vacuum.

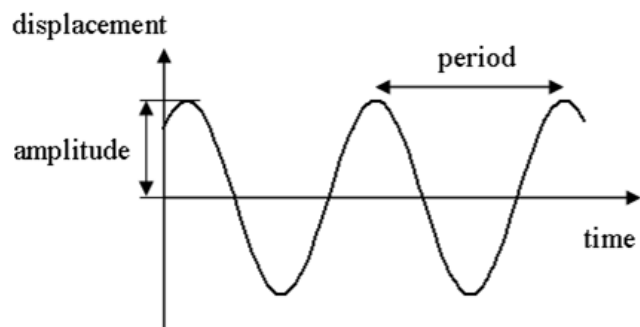

Fig. 7.5. Undamped vibrations

- 2) **Forced Vibrations:** A vibrating object naturally loses energy with time. It must continuously be put back into the vibrations through a force in order to sustain the vibration. A sustained input of energy would be required to keep the back and forth motion going. Thus *when a periodic force is used to maintain the vibrations of an object then such vibrations are called forced vibrations*. For example swing of a child.
- 3) **Resonant Vibrations:** *It is a special type of forced vibration in which the frequency of applied force matches with natural frequency of an object*. In this situation resonance occurs and the amplitude of vibrations increases largely. For example tuning of radio set, swing of a child.
- (a) Tuning of a radio set: There are many stations sending radio waves of various frequencies causing forced oscillations in the circuit of receiver. When the frequency of tuner equals that of waves from particular broadcasting station, the resonance takes place and hence we can hear only that station, whose amplitude is increased.
- (b) During earthquake certain building whose natural frequency are same as the frequency of earthquake collapse due to resonant vibration.

Resonance occurs widely in nature. Some sounds we hear, like when hard objects of metal, glass, or wood are struck, are caused by brief resonant vibrations in the object. Electromagnetic waves are produced by resonance on an atomic scale. Other examples are the balance wheel in a mechanical watch, tidal resonance, acoustic resonances of musical instruments, production of coherent light by optical resonance in a laser etc.

7.3 SIMPLE HARMONIC MOTION (SHM)

It is a special type of motion in which the restoring force is directly proportional to displacement from the mean position and opposes its increase. Applying Newton's second law of motion (force = mass \times acceleration), it can be stated as *a periodic motion in which the acceleration is directly proportional to displacement and is always directed towards mean position*.

In other words, if F is the restoring force and 'y' is the displacement from the mean position, then

$$F = - K y \quad \text{or} \quad a = - \frac{K}{m} y$$

The negative sign indicates that F opposes increase in y and K is constant of proportionality, called force constant. In such motion displacement varies harmonically with time and can be represented in terms of harmonic functions i.e. $\sin\theta$, $\cos\theta$ such as

$$y(t) = A \sin \omega t \text{ or } A \cos \omega t \quad (\theta = \omega t)$$

Here A is the amplitude of SHM and ω is angular frequency.

Examples of SHM are; motion of simple pendulum, cantilever, mass-spring system, swing etc.

Characteristics of SHM:

- The motion should be periodic.
- Force causing the motion is directed toward the equilibrium point (minus sign).
- Acceleration produced is directly proportional to the displacement from equilibrium.

7.4 CANTILEVER

A metallic beam fixed at one end and free to vibrate at other end is called cantilever. The normal configuration of a cantilever is shown in Fig. 7.6.

When it is loaded at free end it vibrates and its edge performs simple harmonic motion. The time taken to complete one vibration is called time period.

The time period is given by

$$T = 2\pi \sqrt{\frac{p}{g}}$$

Where p is the depression of beam (displacement of beam from its unloaded position) and g is acceleration due to gravity.

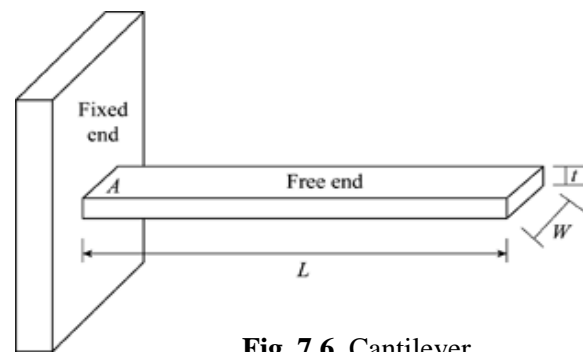

Fig. 7.6 Cantilever

7.5 SOUND WAVES

These are mechanical waves and need medium for their propagation. Sound waves also called pressure waves can be transmitted through solid, liquid or gas. There are three frequency ranges in which sound is categorised:

- Audible:** The sound waves between frequencies 20 Hz to 20 kHz is called audible range and audible to human. It is also called sonic sound.
- Infrasonic:** Sound waves below frequency 20Hz are called infrasonic and are inaudible to human ears. A number of animals produce and use sounds in the infrasonic range. For example elephant, whales, rhinos etc.
- Ultrasonic:** The sound waves with frequency above 20 kHz are called ultrasonic. Bats communicate through ultrasonic waves. These waves also inaudible to human ears.

Properties of sound waves are:-

1. Sound waves are longitudinal mechanical waves.
2. They need material medium for their generation and propagation.
3. They cannot traverse through vacuum so their velocity in vacuum is zero.
4. Their velocity in air at NTP is 332 m/s and it increases with rise in temperature.
5. Sound waves travel faster in solids than in liquids than in gasses.
6. They show the phenomena of reflection, transmission, diffraction etc.

7.6 ACOUSTICS OF BUILDINGS

The branch of physics that deals with study of audible sound including their generation, propagation and properties is called acoustics.

Acoustics of buildings: It deals with construction of public halls, auditoriums, cinema halls etc. for best sound effects.

Generation of Audible Sound: Any object that can produce longitudinal mechanical waves of frequency between 20 Hz to 20 kHz generates audible sound. For example, musical instruments, vibrating fork, human throat (vocal chord) etc.

Propagation of Audible Sound: Audible sound propagates in material medium only. Its velocity is lowest in air and increases with increase in density of the medium. It travels fastest in metals. While travelling in one medium if it meets another medium it gets divided into three parts; reflected part, absorbed part and transmitted part.

Coefficient of Absorption of Sound:

The ratio of sound energy absorbed by a surface to the total sound incident on a surface is called coefficient of absorption or simply absorption coefficient of sound. It is denoted by 'a' and its SI unit is OWU (open window unit). Its value is maximum (=1) for an open window.

$$a = \frac{\text{absorbed sound energy by a surface}}{\text{Total sound energy incident on the surface}}$$

Types of Audible Sound: Two types of audible sound are musical sound and noise.

Musical Sound: The sound that produces pleasant effect on our ears is called musical sound. It is a single sound or multiple sounds having same frequency, wavelength and meeting in same phase.

e.g. Sound of music, chirping of birds etc.

Noise: The sounds that produce unpleasant effect on our ears are called noise. It has irregular amplitude with time. It is generally a combination of multiple sounds of different frequency, wavelength and meeting in different phases.

e.g. sound of horn, thunder etc.

Reverberation:

It is the persistence of sound after the source has stopped emitting sound due to reflection from multiple surfaces.

Reverberation Time:

The time up to which a sound persists in a hall or room after the source has stopped emitting it is called reverberation time.

Standard reverberation time (Sabine's formula): Reverberation time is the time taken by the sound intensity to drop by 60 dB or reduce to its one millionth parts. An American scientist W. C. Sabine developed an equation for calculating the reverberation time as:

$$T = \frac{0.16V}{\sum aS}$$

where V is the volume of the hall in m^3 , a is the average absorption coefficient of room surfaces and S is total surface area of room in m^2 .

$$\text{Here } \sum aS = a_1s_1 + a_2s_2 + a_3s_3 + \dots$$

where a_1, a_2, a_3 etc. are absorption coefficients of different objects in hall and s_1, s_2, s_3 etc. are their surface areas.

Echo:

The repetition of original sound by reflection from a surface is called echo. The echo is produced if the reflected sound reaches our ears after 1/10 of a second. It is different from reverberation as echo is identified as repeated sound due to a time gap of at least 1/10 of a second.

The distance 'd' of reflector/obstacle causing echo is given by

$$d = \frac{v.t}{2}$$

where 'v' is velocity of sound and 't' is time taken by reflected sound to reach our ears.

The minimum distance of obstacle to produce echo thus is given as

$$s = \{332 \times (1/10)\} / 2 = 16.6 \text{ m/s}$$

Thus, the obstacle must be placed at a minimum distance of 16.6 m from the source to produce echo.

Methods to Control Reverberation time:

To control reverberation time the simplest way is to increase absorption in the hall. The methods to control reverberation are:

1. *Provide few open windows in hall-* Open windows are good absorbers of sound and the reverberation time can be controlled by adjusting the number of open windows in the hall.
2. *Cover the floor with carpets-* The carpets are also good absorbers of sound which help in reducing the reverberation time in the hall.
3. *Curtains-* The use of heavy folded curtains on doors and windows allows to control the reverberation time.
4. *Cover the walls-* Covering the walls with absorbing materials like fibre or asbestos sheets etc help in reducing reverberation time.
5. *Using false ceiling-* False ceiling is made of sound absorbing materials which reduces the reverberation in a hall.
6. *Using upholstered cushioned seats in hall-* the seats in the empty hall would also absorb the sound if they are made of good absorbing cushioned material and turn up when no one is sitting on them.
7. *A good number of audience* increases the absorption of hall.

7.7 ULTRASONICS

The sound waves having frequency more than 20 kHz are called ultrasonics. Their characteristics are:

- i. They are high frequency and high energy waves.
- ii. If they are passed through a liquid it is shaken violently.
- iii. They work as catalyst for chemical reactions.
- iv. They can be sent in the form of narrow beam to long distances without loss of energy.
- v. Travelling in one medium if they meet another, they return back in same medium at 180 degree.
- vi. Just like ordinary sound waves, ultrasonic waves get reflected, refracted and absorbed.
- vii. They produce intense heating effect when passed through a substance.

Production of Ultrasonic: The natural producer of ultrasonics is 'Bat'. Another simple method to produce low frequency ultrasonics is 'Galton's whistle'. Two types of oscillators are used to produce ultrasonic sounds: Magnetostriction oscillator, Piezoelectric oscillator.

Applications of Ultrasonic: Ultrasonic waves are used in various fields like; medical for ultrasound, navigation for various purposes, engineering for drilling, cleaning, flaw detection etc. Some important applications of ultrasonic are described below:

- 1) **Drilling:** Ultrasonic is high frequency and high energy wave, so they can be used in applications involving high amount of energy. They can be used to make a drill even in hardest material of world i.e. Diamond. For this a tool bit is attached at lower end of magnetostriction oscillator. The sheet to be drilled is kept below the tool bit. It is driven by a magnetostriction oscillator that creates the vibrations. When oscillator is switched on the tool bit moves up and down that produces enough strain to make a drill in the sheet. The setup of drilling is shown in figure 7.7.

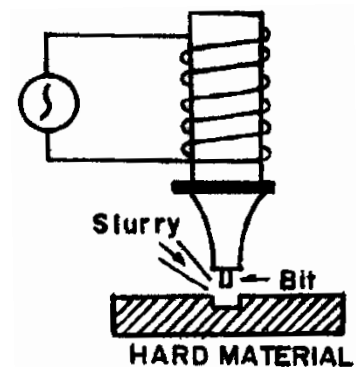

Fig. 7.7 Ultrasonic drilling

- 2) **Ultrasonic welding (cold welding):** The setup is shown in figure 7.8. Cold welding means welding without involvement of heat which is possible only with ultrasonics. A hammer is attached at lower end of magnetostriction oscillator. The sheets to be welded are kept below hammer. When oscillator is switched on hammer strikes the sheets frequently. In case of resonance the molecules of both sheets enter in each other due to high amplitude and welding is performed without involvement of heat. The interface of the two parts is specially designed to concentrate the energy for maximum weld strength.

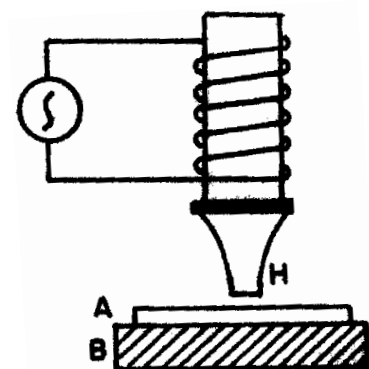

Fig. 7.8 Cold welding

3) **SONAR:** is a technique which stands for **S**ound **N**avigation and **R**anging. It uses ultrasonic for the detection and identification of underwater objects. A powerful beam of ultrasonic is sent in the suspected direction in water. By noting the time interval between the emission and receipt of beam after reflection, the distance of the object can be easily calculated. Measuring the time interval (t) between the transmitted pulses and the received pulse, the distance (d) between the transmitter and the remote object is determined using the formula

$$d = v \times \frac{t}{2}$$

where v is the velocity of sound in sea water. The same principle is used to find the depth of the sea as shown in figure 7.9.

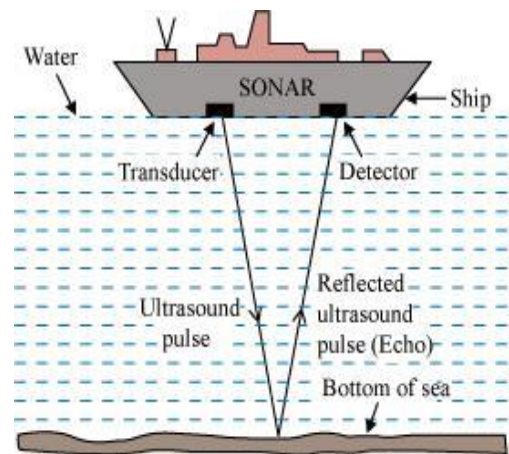

Fig. 7.9 Sound navigation and ranging

Numerical 3. An ultrasonic scanner travelling with a speed of 1.5 km/s in a tissue operating under a frequency of 4.1 MHz. What is the wavelength of sound in the tissue?

Solution:

Given, Velocity (v) = 1.5 km/s = $1.5 \times 1000 = 1500$ m/s

Frequency (ν) = 4.1 MHz = 4.1×10^6 Hz

Using the relation; $v = \nu \lambda$ we can get

$$\text{Wavelength, } \lambda = \frac{v}{\nu} = \frac{1500}{4.1 \times 10^6} = 3.65 \times 10^{-4} \text{ m} = 36.5 \text{ mm}$$

Numerical 4. A man hears his sound again after reflection from a cliff after 1 second. If the velocity of sound is 330 m/s, find the distance of cliff from the man.

Solution: Given

Velocity of sound, $v = 330$ m/s

Time after which sound is heard, $t = 1.0$ s

Let d be the distance of cliff from man.

Total distance travelled by sound in going and coming back from cliff = $2d$

Thus, $2d = v \times t = 330 \times 1 = 330$ m

$$d = \frac{330}{2} = 165 \text{ m}$$

EXERCISES

Fill in the blanks or true/false

1. In _____ waves, matter in the medium moves forward and backward in the same direction in which the wave travels.
2. When the vibrations of a body are maintained by its own elastic forces then such vibrations are called _____.
3. Sound wave cannot get _____ (Reflected /Polarized)
4. Echo is caused due to _____ of sound.
5. Perfect absorber has absorption coefficient of _____ (0 / 1/ infinity).
6. Standard reverberation time is given by _____ formula.
7. _____ waves does not require medium to travel
8. In _____ waves, matter in the medium moves back and forth at right angles to the direction the wave travels.
9. The velocity of sound waves in vacuum is _____.
10. Wave is a form of disturbance. (True / False)
11. In SHM, acceleration is directly proportional to displacement. (True / False)
12. The vibrations in which amplitude of vibrations remains constant are called damped vibration. (True / False)
13. The minimum distance of an obstacle for echo to be heard is 16.6 m. (True / False).
14. Sound waves cannot travel in outer space because these are mechanical waves. (True / False).

Short answer type questions:

1. Define wave motion.
2. Explain types of wave motion?
3. Differentiate between transverse and longitudinal waves.
4. Define amplitude and wavelength of a wave.
5. Give relation between time period and frequency of a wave.
6. Define Simple Harmonic Motion.
7. What is a cantilever?
8. Define acoustics of buildings.
9. What is Sabine's formula?
10. Define ultrasonic waves.
11. Establish the relation between velocity, frequency and wavelength?
12. Give full form of SONAR.
13. Name different types of vibrations.
14. What are resonant vibrations?
15. Explain damped and undamped vibrations?

Long answer questions:

- 1) Define wave motion? Explain transverse and longitudinal wave motion with examples.
- 2) Define the terms; wave velocity, frequency and wave length. Drive the relationship between them.
- 3) Describe simple harmonic motion. Give its characteristics.

- 4) What is a cantilever? Write the formula for its time period.
- 5) What are acoustics and acoustics of buildings?
- 6) Explain the terms: reverberation, reverberation time and echo.
- 7) Define coefficient of absorption of sound? Give its units.
- 8) List various methods to control reverberation time.
- 9) Explain free, forced and resonant vibrations with examples.
- 10) What is ultrasonic wave? Explain their two engineering applications.

Chapter8

OPTICS

Learning Objectives: After studying this chapter the student should be able to;

- Understand light properties, reflection and refraction of light, lens parameters, lens formula and power of a lens.
- Explain total internal reflection, conditions for TIR and its applications.
- Describe microscope, telescope and their uses.

Introduction

Optics is the branch of physics which deals with the study of behavior and properties of light. Light is an electromagnetic wave having transverse nature. Although light has dual nature; particle as well as wave, classical approach considers only wave nature. The wave nature is further simplified in geometric optics, where light is treated as a ray which travels in straight line. Ray optics model includes wave effects like diffraction, interference etc. Quantum optics deals with application of light considered as particles (called photons) to the optical systems. The phenomena of photoelectric effect, X-rays and lasers are explained in the quantum optics (particle nature of light).

Ray Optics (Geometric optics)

Geometrical optics describes the propagation of light in terms of rays. The assumptions of geometrical optics are:

- Light travels in straight-line paths.
- It bends, or split into part, at the interface between two different media.
- It follows curved paths in a medium where refractive index changes.
- It may be reflected, absorbed or transmitted.

8.1 REFLECTION AND REFRACTION OF LIGHT

Reflection of Light

The phenomena of bouncing back of light after striking at a polished surface is called as reflection

Glassy surfaces such as mirrors exhibit reflection. This allows for production of reflected images that can be associated with real or virtual location in space. Figure 8.1 depicts the phenomenon of reflection from a glass-air interface. The light ray incident on a glass mirror at an angle θ_i (angle of incident) and the light ray reflected from the surface at an angle θ_r (angle of reflection).

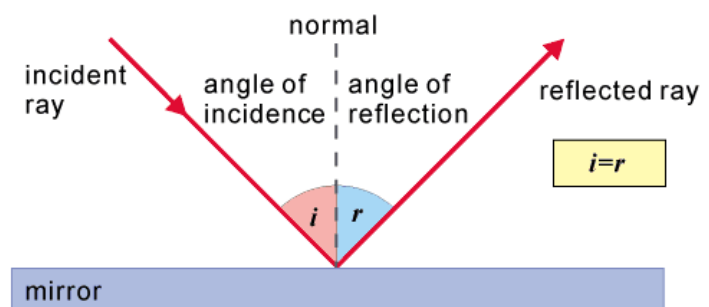

Fig. 8.1 Reflection of light

Laws of reflection:

- 1) The incident ray, reflected ray and the normal, all lie in same plane, and
- 2) The angle of incidence is always equal to angle of reflection i.e. $\theta_i = \theta_r$

Refraction of light

When a light ray passes from one transparent medium to another, it gets deviated from its original path while crossing the interface of two media. *The phenomena of bending of light rays from their original path while passing from one medium to another is called refraction.*

- When light travels from a rarer medium to denser medium, it bends towards the normal.
- When light travels from a denser medium to rarer medium, it bends away from the normal.

It happens when light travels through medium that has a changing index of refraction. Refraction occurs due to change in speed of light as it enters a different media. Figure 8.2 describe the occurrence of refraction at an interface.

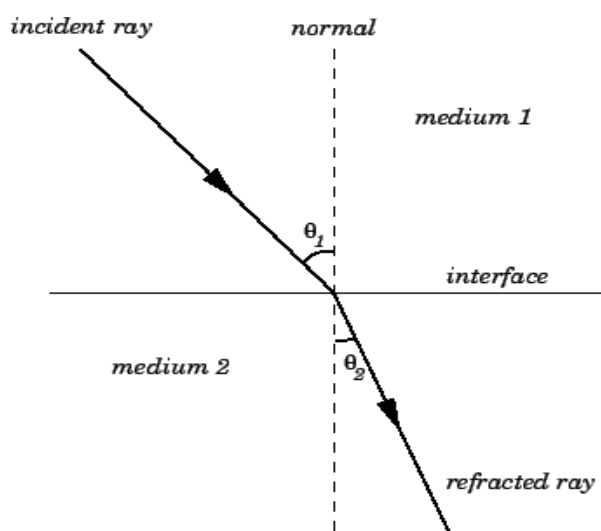

Fig. 8.2 Refraction of light

Laws of refraction:

- 1) The incident ray, the refracted ray and the normal all lie in the same plane.
- 2) The ratio of sine of incidence angle (θ_1) to the sine of refracted angle (θ_2) is a constant for that pair of media and is equal to the **refractive index** of that media. This is also known as **Snell's law**

$${}_1\mu_2 = \frac{\sin \theta_1}{\sin \theta_2} = \frac{\sin i}{\sin r}$$

Where 'i' is the angle of incidence and 'r' is the angle of refraction and ${}_1\mu_2$ is the refractive index of medium 2 w.r.t. medium 1. If medium 1 is vacuum then,

$$\mu = \frac{\sin \theta_1}{\sin \theta_2}$$

When light travels from air (vacuum) to a medium then refractive index of the medium can be written as

$$\mu = \frac{c}{v}$$

where c is the velocity of light in air (vacuum) and v is the velocity of light in the medium. For example, the refractive index of water is 1.333, meaning that light travels 1.333 times slower in the water than in vacuum. Thus, the refractive index of a material is a dimensionless number that describes how light propagates through that medium.

The Snell's law is used to find the deflection of light rays when they pass through different media. It is used to produce dispersion spectra through a prism since light rays having different frequencies have slightly different refractive index in most materials.

Lens and lens formula

Lens is an optical device based on phenomenon of refraction. A lens is a transparent medium bounded by two refracting surfaces. It can produce two types of rays- converging and diverging rays. Convex lens is converging while concave lens is diverging.

Terms related in study of lenses:

1. **Centre of curvature:** The center of curvature of a lens is the centre of sphere which forms a part of the spherical surface of the lens.
2. **Radius of curvature:** The radius of the sphere of the spherical surface of lens is called radius of curvature. It is the distance of the vertex of the lens from the center of curvature.
3. **Principal axis:** The principal axis of a lens is an imaginary line that is perpendicular to the vertical axis of the lens. Principal focus of the lens lies on this axis. All rays parallel to the principal axis that are incident on the lens, would either converge (if lens is converging) to, or diverge (if the lens is diverging) from, the principal focus.
4. **Optical centre:** Optical centre is the centre of the lens lying on the principal axis. If a light ray passes through optical centre, it goes undeviated.
5. **Principal focus:** When the parallel rays are incident on a lens, they either meet or appear to meet at a point on the principal axis, that point is called principal focus.
6. **Focal length (f):** The distance of principal focus from the optical centre is called focal length. In other words, focal length is equal to the image distance when the object is at infinity.
7. **Image:** If two or more rays passing from a point gets refracted through a lens and converges or appears to diverge to a point then that point is called the image of first point. The image can be real or virtual. In real image, rays actually meet at the second point, while in virtual image; the rays appear to diverge from the second point.

Lens formula

The formula which gives relation between focal length (f), object distance (u) and image distance (v) as

$$\frac{1}{f} = \frac{1}{v} - \frac{1}{u} \quad \Rightarrow \text{This is called lens formula.}$$

Linear magnification: the ratio of size of image to the size of object is called as linear magnification of a lens. It is given by; $m = \frac{I}{O}$ or $\frac{v}{u}$ and holds for both convex and concave lenses and for real as well as virtual images.

Power of lens

The ability of a lens to converge or diverge the light rays is called as power of lens.

Mathematically, power of a lens is defined as *the reciprocal of the focal length*.

$$P = \frac{1}{f} \quad (f \text{ is taken in metre})$$

The unit of power of lens is m^{-1} which is called **dioptr**e and indicated by symbol 'D'. In other words, one dioptr is the power of a lens of one metre focal length.

The power of a convex lens is positive and that of concave lens is negative. If two lenses are combined (placed in contact), the focal length of the combination is given by

$$\frac{1}{F} = \frac{1}{f_1} + \frac{1}{f_2}$$

Thus the power of combination becomes sum of power of individual lenses. i.e.

$$P = P_1 + P_2$$

$$\text{In general, } P = P_1 + P_2 + P_3 + \dots$$

8.2 TOTAL INTERNAL REFLECTION (TIR)

When light is goes from denser medium to rare medium and the angle of incidence is greater than critical angle, the light get completely reflection in the same medium. This phenomenon is known as total internal reflection.

There are two essential conditions for TIR:

1. The light should travel from a denser medium to a rarer medium.
2. The angle of incidence in the denser medium should be greater than the critical angle.

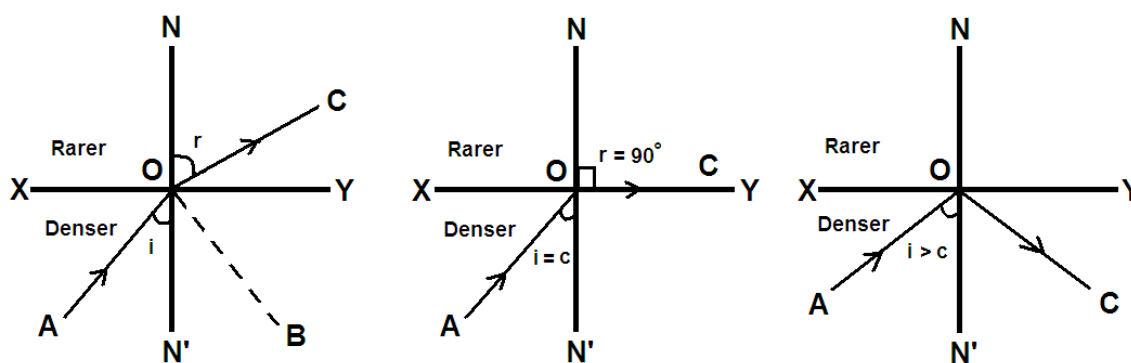

Fig. 8.3 Total internal reflection

The angle of incidence for which the angle of refraction becomes 90° is called as *critical angle* (θ_c). At the critical angle of incidence, the refracted ray travels along the boundary between the two media i.e. the angle of refraction becomes 90° . For angle of incidence greater than critical angle light is totally reflected as shown in Fig. 8.3.

The critical angle for a material depends upon the refractive index. Higher the refractive index, the lower the critical angle. It can be calculated using the following formula:

$$\sin \theta_c = \frac{1}{\mu}$$

Where θ_c is the critical angle and μ is the refractive index.

Applications of TIR

1. TIR is the basic principle of optical fibers which are used as transmission media in sending telecommunication signals and images in endoscopes.
2. Automotive rain sensors work on the principle of TIR, which control automatic windscreen wipers.
3. Prisms in binoculars also form erect images based on total internal reflection.
4. Some multi-touch screens also use TIR to pick up multiple targets.
5. Optical fingerprinting devices used to record fingerprints without the use of ink are also based on TIR.
6. The bright shining of diamonds is also a result of total internal reflection.
7. Formation of mirage.

8.3 OPTICAL INSTRUMENTS

An optical instrument is a device which is used to view the objects. The eye is natural optical system. In addition to it, other instruments are devised to increase the range a human's viewing ability. The optical instruments are an aid to the eye. They consist of an arrangement of lenses, prisms or mirrors which enables to see better than what we can see with the naked eye. These can be of two types:

1. When the real image is formed on screen as in case of photographic camera, overhead projector etc.
2. When a virtual image is formed and can be seen directly with eye as in telescopes, microscopes, binoculars etc.

a) Microscope: *A microscope is an optical instrument which enables us to see magnified image of very small objects.* A microscopic object is invisible to the eye unless aided by a microscope. Fig.8.4 shows the view of a microscope.

There are two types of microscope:

1. **Simple microscope.** It is also known as magnifying glass. It is made of only one convex lens and the object is so adjusted before the focal point that the image is formed at least distance of distinct vision.
2. **Compound microscope.** The magnification produced by a simple microscope is small and is only governed by the focal length of lens. To produce large magnification, a compound microscope is used in which magnification is obtained in two stages by the use of two convex lenses.



Fig. 8.4 A microscope



Fig. 8.5 A Telescope

Telescope: A telescope is an optical instrument which is used to see distant objects clearly.

There are three types of telescopes:

1. **Astronomical:** It is used to see astronomical heavenly objects like stars and planets. The image formed in an astronomical telescope is inverted.
2. **Terrestrial:** Astronomical telescope forms an inverted image which is not suitable to see the terrestrial objects like buildings, trees etc. For seeing the distant objects lying on earth, the final image should be erect. A terrestrial telescope (Fig. 8.5) forms an erect image and makes use of three convex lenses.
3. **Galilean** (modification of terrestrial telescope): It is a modified version of terrestrial telescope which also forms erect image but with the use of only two lenses.

8.4 USES OF MICROSCOPE AND TELESCOPE

a) Uses of Microscope

1. Biological scientists use microscope to see microorganisms and their behavior.
2. Doctors use microscope to see and examine blood cells and bacteria.
3. Forensic science experts use microscope to analyze the evidences of crimes.
4. Jewelers and watch makers use it to see the details of parts they are working with.
5. Environmentalist uses it to test the soil and water samples for presence of pollutants.
6. Geologist uses it to test the composition of different types of rocks.
7. These are used in various laboratories.

b) Uses of Telescope

1. Astronomical objects are seen by using telescope by astronomers.
2. They found use in terrestrial applications also. They are used in laboratories to perform different experiments and finding values of different quantities.
3. Spectrometry uses telescopes to find wavelength of light and spectral lines etc.
4. It is used in spy glasses and long focus camera lenses.

Solved Numericals

Numerical 1. A lens is having power of +4 D. What is its focal length?

Solution: Given, Power (P) = +4 D

$$\text{We know that } P = \frac{1}{f}$$

$$\text{Therefore, } 4 = \frac{1}{f} \text{ or } f = \frac{1}{4} \text{ m} = 0.25 \text{ m} = 25 \text{ cm}$$

Thus, focal length of lens is 25 cm.

Numerical 2. An object is kept at distance of 30 cm from a convex lens of focal length 0.2 m. Find the position of the image formed.

Solution: Given, distance of object, $u = -30 \text{ cm} = -0.3 \text{ m}$, and $f = 0.2 \text{ m}$

The lens formula is $\frac{1}{f} = \frac{1}{v} - \frac{1}{u}$

or

$$\frac{1}{v} = \frac{1}{f} + \frac{1}{u} = \frac{1}{0.2} + \frac{1}{(-0.3)} = 5 - 3.33 = 1.67$$

$$v = \frac{1}{1.67} = 0.598 = 0.6 \text{ m} = 60 \text{ cm}$$

Numerical 3. A light wave has wavelength of 600 nm in vacuum. What is the wavelength of the light as it travels through water (index of refraction = 1.33)?

Solution:

Given, wavelength (λ) = 600 nm = $600 \times 10^{-9} \text{ m}$ (1 nm = 10^{-9} m).

The wavelength of light that travels through a medium of refractive index n changes by expression

$$\lambda_n = \frac{\lambda}{n} = \frac{600 \times 10^{-9}}{1.33} = 451 \times 10^{-9} \text{ m} = 451 \text{ nm}$$

* * * * *

EXERCISES

Fill in the blanks and true/false

1. The speed of light in vacuum is _____.
2. Spectrum is formed due to _____ of light.
3. A _____ lens is thick at centre and thin at ends.
4. A transparent medium bound by two curved surfaces is called _____ (lens/mirror).
5. A lens is an optical device based on _____ (reflection/ refraction).
6. Changing path of light while entering second medium is called _____.
7. Power of a lens is measured in _____ .
8. Power of a lens is inverse of _____ .
9. Simple microscope uses _____ (one/two) number of lens.
10. Simple microscope is also known as magnifying glass (True/ False).
11. Telescope that uses three lenses is called terrestrial telescope. (True / False)
12. An instrument that forms image on screen is called camera. (True / False)
13. Refractive index of a medium is constant. (True / False)
14. Two lenses are used in a simple microscope. (True / False)

Short answer questions:

1. Define reflection and state laws of reflection.
2. Define refraction and state laws of refraction.
3. Explain total internal reflection (TIR).
4. What is critical angle?
5. Define principal focus of a lens.
6. Write is lens formula.
7. Define power of a lens.
8. Give the relation between focal length and power of a lens.

Long answer questions:

1. Define refractive index? How it is related to Snell's law.
2. Describe total internal reflection. Give two applications of TIR.
3. What is critical angle? Explain conditions necessary for TIR.
4. What is a microscope? Give its types and uses.
5. What is a telescope? Give various uses of telescope.

Chapter 9

ELECTROSTATICS

Learning Objectives: After studying this chapter, the student should be able to;

- Understand fundamental of charges at rest, properties of point charges;
- Explain conservation and quantization of charges;
- Relate the properties leading charge storage capacity of the electronic devices using static charges.

Electrostatics is the branch of physics which deals with the study of charges at rest.

9.1. ELECTRIC CHARGE

Electric Charge: it is the physical property of matter that causes it to experience force when placed in an electromagnetic field. There are two types of charges.

(1) **Positive charge:** e.g. proton, alpha particle

(2) **Negative charge:** e.g. electron, etc.

Charge on electron is smallest unit of charge.

SI unit of charge is coulomb (C).

Charge on electron (e) = $- 1.6 \times 10^{-19} \text{ C}$
Charge on proton (P) = $+ 1.6 \times 10^{-19} \text{ C}$

Like charges repel each other and unlike charges attract each other. i.e.

+ve	+ve	Repel
-ve	-ve	Repel
+ve	-ve	Attract
-ve	+ve	Attract

Conservation of Charge

Charge conservation is the principle that *total electric charge in an isolated system always remains constant*. This also means that no net charge can be created or destroyed. When an atom is ionized, equal amounts of positive and negative charges are produced. Hence the algebraic sum of charges before and after remains the same.

Quantization of Charges

Charge quantization is the principle that the total charge on any object is an integral multiple of the elementary charge (e). Thus, an object's charge can be exactly $\pm ne$ (i.e. $1 e, -1 e, 2 e$, etc.).

Or $Q = \pm ne$

9.2. COULOMB LAW OF ELECTROSTATICS

It states that force of interaction between two point charges is

- (i) Directly proportional to magnitude of charges and
- (ii) Inversely proportional to the square of the distance between them.

Let F is force between two charges q_1 and q_2 . Then

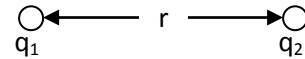

Figure 9.1

$$F \propto q_1 q_2$$

$$F \propto \frac{1}{r^2}$$

$$\Rightarrow F \propto \frac{q_1 q_2}{r^2} \dots\dots\dots(1)$$

$$F = K \frac{q_1 q_2}{r^2} \dots\dots\dots(2)$$

where K is constant of proportionality and its value is given as

$$K = \frac{1}{4\pi \epsilon_0} = 9 \times 10^9 \text{ Nm}^2/\text{C}^2 \text{ (in SI units system)}$$

Now from equation (2)

$$F = \frac{q_1 q_2}{4\pi \epsilon_0 r^2} \dots\dots\dots(3)$$

Here ϵ_0 is electrical permittivity of vacuum. Its value is $8.854 \times 10^{-12} \text{ N}^{-1}\text{m}^{-2}\text{C}^2$.

Let $q_1 = q_2 = q$ (say)

and $r = 1 \text{ m}$

then from equation (3), $F = 9 \times 10^9 \text{ N}$

Thus *one coulomb is that much charge which produces a force of $9 \times 10^9 \text{ N}$ at a unit charge placed at a distance of 1 m.*

Smaller units of charge;

$$\text{milli coulomb (mC)} = 10^{-3} \text{ C.}$$

$$\text{micro coulomb } (\mu\text{C}) = 10^{-6} \text{ C.}$$

9.3. ELECTRIC FIELD

It is the space around the charge in which force of attraction or repulsion can be experienced by another charge.

Electric field intensity

At point is defined as the force acting on a unit positive charge at that point.

$$\vec{E} = \frac{\vec{F}}{q_0}$$

• A unit positive charge is also called as test charge

The value of q_0 should be very small. Its SI unit is N /C (newton per coulomb)

Electric Lines of Force:

It is the path along which the isolated charge moves in electric field if it is free to do so. These are imaginary continuous line in an electric field such that tangent to it at any point gives the direction of electric force at that point (Fig. 9.2).

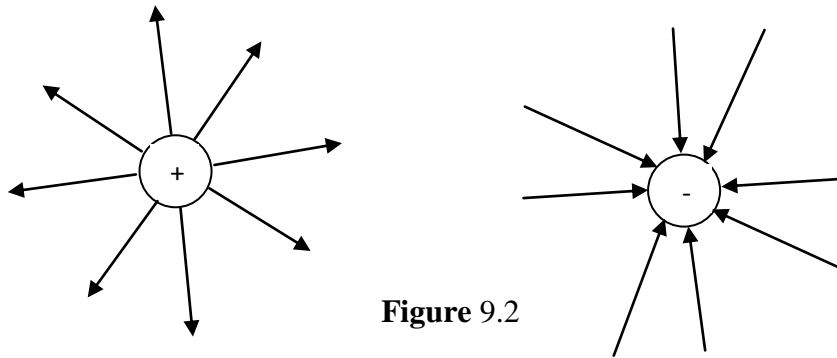

Figure 9.2

Properties of electric lines of force

- Electric lines of force originate from a +ve charge and terminate to a -ve charge.
- The tangent to the line of force indicates the direction of the electric field and electric force.
- Electric lines of force are always normal to the surface of charged body.
- Electric lines of force contract longitudinally and expand laterally.
- Two electric lines of force cannot intersect each other.
- Two electric lines of force proceeding in the same direction repel each other.
- Two electric lines of force proceeding in the opposite direction attract each other.
- There are no lines of force inside the conductor, so electric field inside conductor is zero.

9.4. ELECTRIC FLUX

It is the measure of distribution of electric field through a given surface. Electric flux is defined as *total number of electric lines of force passing per unit area normal to the surface*. It is denoted by ϕ (phi).

Consider small elementary area \vec{ds} on a closed surface S. Electric field \vec{E} exit in the space. If θ is the angle between \vec{E} and area vector \vec{ds} as then

$$\phi = \oint \vec{E} \cdot \vec{ds} \text{ is called electric flux.}$$

GAUSS'S LAW

It states that *net electric flux of an electric field over a closed surface is equal to the net charge enclosed by the surface divided by ϵ_0 i.e.*

$$\phi = \oint \vec{E} \cdot \vec{ds}$$

$$\phi = \oint_s E ds \cos \theta = \frac{q}{\epsilon_0}$$

Proof: Consider a closed surface S having a charge q placed at a point O inside a closed surface as shown in Fig. 9.3. Take a point P on the surface and consider a small area ds around P.

Let $OP = r$

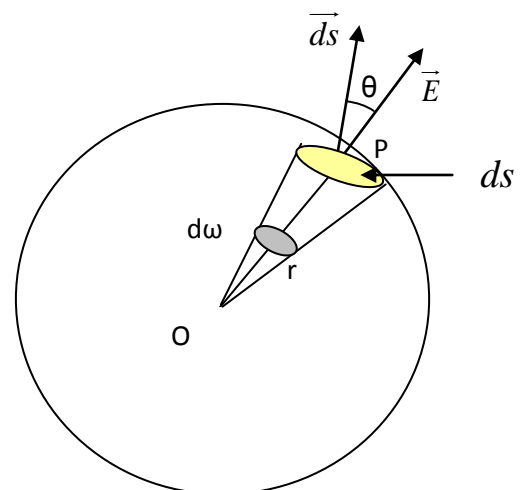

Figure 9.3

Then Electric field at P is

$$E = \frac{q}{4\pi \epsilon_0 r^2} \dots\dots\dots(1)$$

Now electric flux

$$\phi = \oint_s E ds \cos \theta$$

Putting value of E we get

$$\phi = \oint_s \frac{q}{4\pi \epsilon_0 r^2} ds \cos \theta$$

$$\phi = \frac{q}{4\pi \epsilon_0} \oint_s \frac{ds \cos \theta}{r^2}$$

$$\phi = \frac{q}{4\pi \epsilon_0} \oint_s d\omega$$

$$\phi = \frac{q}{4\pi \epsilon_0} .4\pi$$

$$\phi = \frac{q}{\epsilon_0}$$

Hence, $\phi = \oint_s E ds \cos \theta = \frac{q}{\epsilon_0}$

$$\therefore \frac{ds \cos \theta}{r^2} = d\omega$$

\therefore Total Solid angle = 4π

Applications of Gauss's Law:

Electric field due to a point charge:

Consider a point charge q . We want to find electric field at point P at a distance of r from it. Construct a spherical surface of radius r . This is called as Gaussian surface. Consider small area dS on the surface. Let θ is angle between \vec{E} and Area vector as shown in Fig. 9.4.

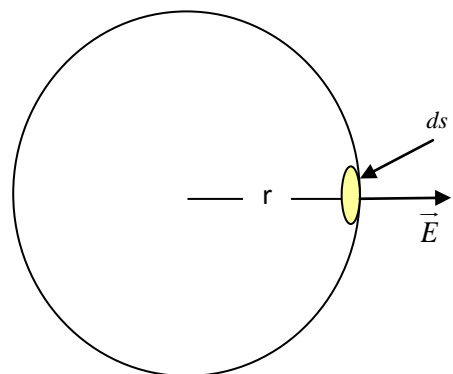

Figure 9.4

Now flux $\phi = \oint_s E ds \cos \theta = \frac{q}{\epsilon_0}$

($\because \theta = 0$)

$$E \oint_s ds = \frac{q}{\epsilon_0}$$

$$\Rightarrow E .4\pi r^2 = \frac{q}{\epsilon_0}$$

(\because Area of Sphere = $4\pi r^2$)

$$\Rightarrow \boxed{E = \frac{q}{4\pi \epsilon_0 r^2}}$$

Thus the electric intensity decreases with increase in distance.

9.5. CAPACITOR

Capacitor is an electronic component that stores electric charge.

Capacitance

Of a capacitor is defined as the ability of a capacitor to store the electric charge.

As potential is proportional to charge

$$V \propto q$$

or $q \propto V$

$$q = CV$$

$$C = \frac{q}{V}$$

Unit of capacitance: farad (F), microfarad

Grouping of Capacitors

Series Grouping:

A number of capacitors are said be connected in series if -ve plate of one capacitor is connected to the +ve plate of other capacitor and so on. In this grouping, current is same on each capacitor.

Consider three capacitors of capacitances C_1, C_2, C_3 in series. Let V is total applied voltage. If $V_1, V_2, V_3 \rightarrow$ voltage drops across C_1, C_2, C_3 as shown in fig. 9.5.

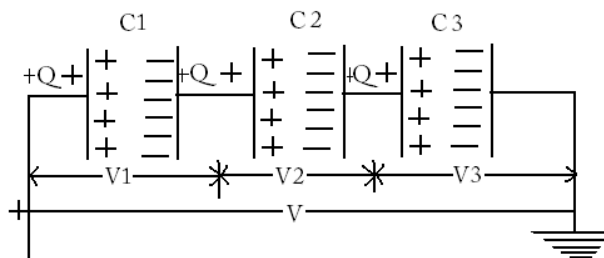

Figure 9.5

$$\text{Then } V = V_1 + V_2 + V_3 \text{ ----- (1)}$$

$$\text{Now } C = \frac{q}{V} \Rightarrow V = \frac{q}{C}$$

$$\text{So, } V_1 = \frac{q}{C_1}, V_2 = \frac{q}{C_2}, V_3 = \frac{q}{C_3}$$

Putting in Equation (1)

$$\frac{q}{C} = \frac{q}{C_1} + \frac{q}{C_2} + \frac{q}{C_3}$$

$$\frac{q}{C} = q \left(\frac{1}{C_1} + \frac{1}{C_2} + \frac{1}{C_3} \right)$$

$$\frac{1}{C} = \frac{1}{C_1} + \frac{1}{C_2} + \frac{1}{C_3}$$

So the total capacitance decreases in series grouping.

The reciprocal of the equivalent capacitance of two capacitors connected in series is the sum of the reciprocals of the individual capacitances.

Parallel Grouping:

A number of capacitors are said to be connected in parallel if +ve plate of each capacitor is connected to the +ve terminal of battery and -ve plate of each capacitor is connected to the -ve terminal of battery. In this grouping voltage across each capacitor is same.

Consider three capacitors of capacitances C_1, C_2, C_3 connected in parallel and V is applied voltage.

$q_1, q_2, q_3 \rightarrow$ charges on capacitors C_1, C_2, C_3 as shown in fig. 9.6

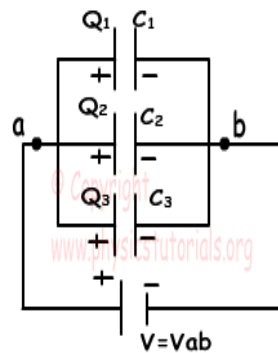

Figure 9.6

So

$$q = q_1 + q_2 + q_3 \text{ ----- (1)}$$

Now $C = \frac{q}{V}$ or $q = CV$

$\therefore q_1 = C_1 V, \quad q_2 = C_2 V, \quad q_3 = C_3 V$

Put in equation (1)

$$CV = C_1 V + C_2 V + C_3 V$$

$$CV = (C_1 + C_2 + C_3) V$$

$$C = C_1 + C_2 + C_3$$

So the total capacitance increases in parallel grouping.

The equivalent capacitance of capacitors connected in parallel is sum of the individual capacitance.

Solved Numerical

Example 1. Calculate the Coulomb force between two protons separated by a distance of 1.6×10^{-15} m.

Solution: Given, 2 protons;

$$\text{Charge on Proton} = 1.6 \times 10^{-19} \text{ C}$$

$$\text{Thus, } q_1 = q_2 = 1.6 \times 10^{-19} \text{ C}$$

$$\text{Distance, } r = 1.6 \times 10^{-15} \text{ m}$$

$$\text{Also } \frac{1}{4\pi\epsilon_0} = 9 \times 10^9 \text{ Nm}^2/\text{C}^2$$

$$\text{Now } F = \frac{1}{4\pi\epsilon_0} \frac{q_1 q_2}{r^2}$$

$$F = \frac{9 \times 10^9 \times 1.6 \times 10^{-19} \times 1.6 \times 10^{-19}}{(1.6 \times 10^{-15})^2}$$

$$F = 90 \text{ N}$$

Example 2. Calculate the force between an alpha particle and a proton separated by distance of 5.12×10^{-15} m.

Solution: Given, $q_1 =$ Charge on alpha particle $= 2 \times 1.6 \times 10^{-19} \text{ C}$

$$q_2 = \text{Charge on proton} = 1.6 \times 10^{-19} \text{ C}$$

$$\text{distance, } r = 5.12 \times 10^{-15} \text{ m}$$

$$\frac{1}{4\pi\epsilon_0} = 9 \times 10^9 \text{ Nm}^2/\text{C}^2$$

Now

$$F = \frac{1}{4\pi\epsilon_0} \frac{q_1 q_2}{r^2}$$

$$F = \frac{9 \times 10^9 \times 3.2 \times 10^{-19} \times 1.6 \times 10^{-19}}{(5.12 \times 10^{-15})^2}$$

$$F = 17.58 \text{ N}$$

Example 3. Three capacitors of capacitances $3 \mu\text{F}$, $2 \mu\text{F}$ and $4 \mu\text{F}$ are connected with each other. Calculate total capacitance (a) in Series grouping (b) in Parallel grouping.

Solution: Given,

$$C_1 = 3 \mu\text{F}, \quad C_2 = 2 \mu\text{F} \quad \text{and} \quad C_3 = 9 \mu\text{F}$$

In Series grouping

$$\frac{1}{C_{\text{tot}}} = \frac{1}{C_1} + \frac{1}{C_2} + \frac{1}{C_3}$$

$$\begin{aligned}\frac{1}{C_{\text{tot}}} &= \frac{1}{3} + \frac{1}{2} + \frac{1}{9} \\ &= \frac{17}{18} \mu\text{F} \\ \therefore C_{\text{tot}} &= \frac{18}{17} = 1.06 \mu\text{F}\end{aligned}$$

In Parallel grouping

$$\begin{aligned}C_{\text{tot}} &= C_1 + C_2 + C_3 \\ C_{\text{tot}} &= 3 + 2 + 9 \\ C_{\text{tot}} &= 14 \mu\text{F}\end{aligned}$$

Example 4. Three capacitors 1 F, 2 F, and 3 F are joined in series first and then in parallel. Calculate the ratio of equivalent capacitance in two cases.

Solution: Given,

$$C_1 = 1 \text{ F}, \quad C_2 = 2 \text{ F}, \quad C_3 = 3 \text{ F}$$

In series grouping

$$\begin{aligned}\frac{1}{C_s} &= \frac{1}{C_1} + \frac{1}{C_2} + \frac{1}{C_3} \\ \frac{1}{C_s} &= \frac{1}{1} + \frac{1}{2} + \frac{1}{3} \\ \frac{1}{C_s} &= \frac{11}{6} \\ \therefore C &= \frac{6}{11} \text{ F}\end{aligned}$$

In Parallel grouping

$$\begin{aligned}C_p &= C_1 + C_2 + C_3 \\ C_p &= 1 + 2 + 3 \\ C_p &= 6 \text{ F}\end{aligned}$$

$$\therefore \text{Ratio} \quad \frac{C_p}{C_s} = \frac{6}{\frac{6}{11}}$$

$$\text{or} \quad \frac{C_p}{C_s} = 11$$

EXERCISES

Fill in the blanks

- 1) As per Coulomb's law, force of attraction or repulsion between two point charges is proportional to product of the magnitude of charges.
- 2) A device which stores charge is called
- 3) 1 micro farad ($1 \mu\text{F}$) is equal to farad.
- 4) SI unit of charge is
- 5) The unit of capacitance is
- 6) Unit of electric field intensity is

Short Answer Questions

1. Define electric field.
2. What are electric lines of force?
3. Define the term capacitance.
4. What is electric flux?
5. Define capacitor.
6. What do you mean by electric potential?
7. Define electric intensity.
8. Explain properties of electric lines of force.
9. Explain Gauss's law.
10. Define electric charge and its types.
11. Find the total capacitance when three capacitors each of $2 \mu\text{F}$ are joined in (i) series, (ii) parallel?
12. What will be Coulomb's force between 2 point charges $10 \mu\text{C}$ and $5 \mu\text{C}$ placed at a distance of 150 cm?

Long Answer Type Question

1. Calculate total capacitance when capacitors are connected in series and parallel grouping.
2. State and prove Gauss law.
3. Using Gauss theorem find electric field intensity due to a point charge.
4. State Coulomb's law of electrostatics.
5. The force between two charges is 120 N. What will be the force, if the distance between the charges is doubled?

Chapter 10

CURRENT AND ELECTRICITY

Learning Objectives: After studying this chapter, the learner should be able to;

- Describe electric current and types of current; AC and DC.
- Define resistance, combination of resistances; series and parallel.
- State Ohm's law, Kirchoff's law and their applications

10.1 ELECTRIC CURRENT AND ITS UNITS

In a conductor, there are many free electrons. These electrons are in random motion but there is no net motion along the conductor. But if the two ends of a conductor are at different potentials, the charge will start flowing from one end of conductor to the other end. Therefore, the free electrons (charge) which were moving randomly will now move towards positive terminal of the battery and constitute a current. Hence a potential difference is always needed to make charge move from one end of the conductor to the other end of the conductor.

In a conductor the motion of the free electrons give rise to the electric current as shown in Fig. 10.1.

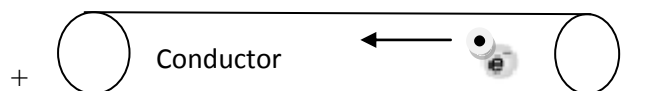

Figure 10.1

Electric current passing through a conductor is *the rate of flow of charge passing through it*. If a charge of q units passes through any cross section of the conductor in t seconds. The current (I) flowing through the wire is given by the formula

$$I = \frac{\text{Charge}}{\text{time}} = \frac{q}{t}$$

The direction of current is the direction of flow of positive charge i.e. opposite to the direction of flow of electron.

Unit: ampere (A)

In the relation

$$I = \frac{q}{t}$$

If the charge is measured in coulombs and time is measured in seconds then the unit of current will be ampere.

Where 1 ampere (A) = $\frac{1 \text{ coulomb}}{1 \text{ sec}}$

One Ampere: *The current flowing through the conductor is said to be of one ampere if one coulomb of charge flows through the conductor in one second.*

Electric Potential difference (V)

Electric potential between two points is defined as the work done in moving a unit positive charge from one point to other against the electric field.

SI unit: volt (V)

One Volt:

$$1 \text{ V} = \frac{1 \text{ joule}}{1 \text{ coulomb}}$$

So, electric potential difference is said to be 1 V, if 1 J work is done in moving 1 C charge from one point to another point. It is defined as energy consumption of one joule per electric charge of one coulomb.

Direct Current (DC)

Direct current in an electric wire is that which flow in only one direction. It is the unidirectional flow of current. The electric current flowing through a semi-conductor diode is an example of direct current. Direct current (DC) is produced by sources such as batteries, fuel cells and solar cells and cannot travel over long distances since it has more loss of energy.

The frequency of DC is zero and it has a single polarity. In direct current the electron flows from negative end of the battery to the positive end of the battery.

Symbol of DC voltage source

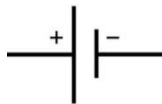

It can be shown as Fig. 10.2.

DC form is used in low voltage apparatus like charging batteries, cell phones, automotive apparatus, aircraft apparatus and other low voltage low current apparatus.

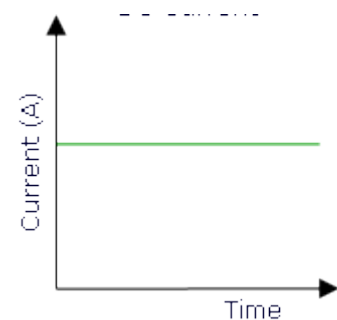

Figure 10.2

Alternating current (AC)

AC is current that reverses the direction periodically and also has a magnitude that varies continuously with time.

AC is used in our homes. Power stations generate AC because it is easy to low and raise the voltage with the help of transformers. In North America the frequency of AC is 60 Hz and in India it is 50 Hz. The AC in our home is sinusoidal in nature.

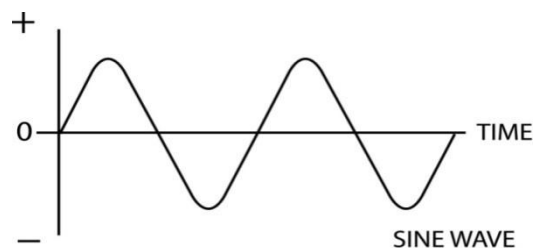

Figure 10.3

The radio frequency current in antennas and transmission lines are the examples of AC.

Symbol of AC



It is produced by an alternator and has more power and can be easily transferred from one place to another.

10.2 OHM'S LAW

According to Ohm's law "*The current flowing through a conductor is always directly proportional to the potential difference between the two ends if the physical condition (temperature, pressure etc.) of the conductor remains the same*".

If I is the current passing through a conductor and V is the potential difference between the ends of the conductor having resistance R , then

$$V \propto I$$

$$V = R I$$

$$\frac{V}{I} = R$$

Therefore, $R = \frac{V}{I} = \frac{\text{potential difference}}{\text{electric current}}$

where R is a constant and is called electric resistance.

The value of R depends upon nature, dimension and temperature of the conductor.

$$V = I R$$

Therefore $I = \frac{V}{R}$

If a graph is drawn between current (I) and the potential difference (V) it will be a straight line for a conductor (Fig. 10.5).

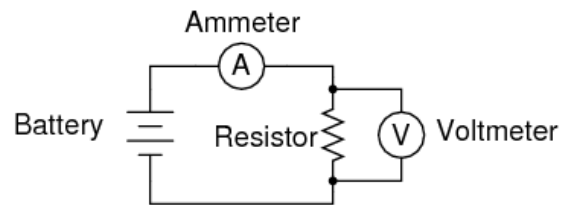

Figure 10.4

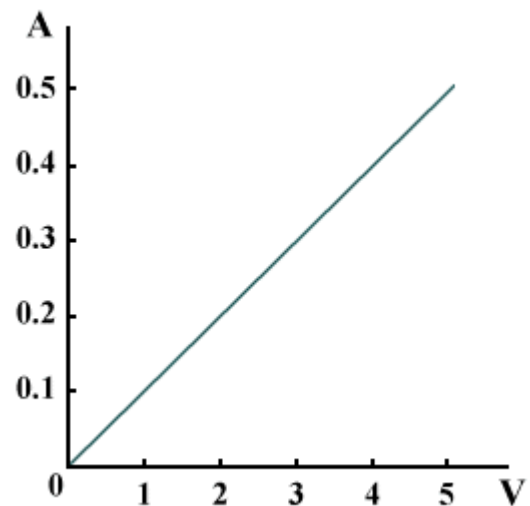

Figure 10.5

10.3 RESISTANCE (R)

The *opposition to the flow of electric current in an electric circuit is called resistance*. Therefore, it is the measure of the difficulty to pass an electric current through the circuit.

$$R = \frac{V}{I} = \frac{\text{potential difference}}{\text{electric current}}$$

If V is measured in volts and I is measured in amperes then the resistance R is measured in ohms.

Symbol: 

Unit: ohms (Ω)

One ohm:

$$1 \text{ ohm} = \frac{1 \text{ volt}}{1 \text{ ampere}}$$

Therefore, one ohm is the resistance of conductor in which a current of one ampere flows through it when the potential difference of one volt is maintained between its two ends.

Specific Resistance (Definition and Units)

The resistance of a conductor depends on following factors;

(i) The resistance of a given conductor is directly proportional to its length i.e.

$$R \propto l \quad \dots\dots\dots (1)$$

ii) The resistance of a given conductor is inversely proportional to its area of cross-section.

$$R \propto \frac{1}{A} \quad \dots\dots\dots (2)$$

By combining equation (1) and (2), we get

$$R \propto \frac{l}{A}$$

$$R = \rho \frac{l}{A}$$

or

where ρ (rho) is a constant and known as specific resistance or resistivity of the material. The resistivity of a material does not depend on its length or thickness. It depends on the nature of the material.

If $l = 1 \text{ m}$ and $A = 1 \text{ m}^2$ then from above equation

$$\rho = R$$

Thus *resistivity of the material is the resistance of a conductor having unit length and unit area of cross- section.*

Units: ohm-m (Ωm)

Conductivity: *It is the degree to which an object conducts electricity.* This is the reciprocal of the resistivity,

$$\sigma = \frac{1}{\rho}$$

Where, σ is the conductivity and ρ is the resistivity of the conductor.

Unit: siemens per metre or mho per metre

Conductance (G): It is the reciprocal of the resistance and it is a measure of ease with which the current flows through an object.

$$G = \frac{1}{R}$$

where

G = Conductance

R = Resistance

Unit: mho

10.4 COMBINATION OF RESISTANCES

1. Series combination

The resistance are said to be connected in series if the same current passes through all the resistances and the potential difference is different across each resistance.

Let three resistances R_1 , R_2 , R_3 be connected in series as shown in the Fig. 10.6

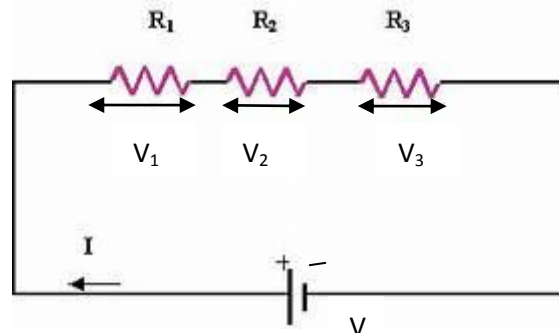

Figure 10.6

Let

V = Voltage applied across the series combination

I = Current passing through the circuit

Clearly current I is same throughout the circuit

Let V_1 , V_2 , V_3 be the potential difference across R_1 , R_2 , R_3 respectively. Then, according to Ohm's law

$$V = I R$$

where R is the total resistance in series

Now

$$V = V_1 + V_2 + V_3 \quad \text{----- (1)}$$

Then by Ohm's law

$$V_1 = I R_1$$

$$V_2 = I R_2$$

$$V_3 = I R_3$$

Putting the values of V_1 , V_2 and V_3 in equation (1) we get

$$I R = I R_1 + I R_2 + I R_3$$

$$I R = I (R_1 + R_2 + R_3)$$

$$R = (R_1 + R_2 + R_3)$$

Thus the combined resistances when they are connected in series is the sum total of the individual resistances.

2. Parallel Combination

The resistances are said to be connected in parallel if the potential difference across each resistance is the same but the current passing through each resistance is different.

Let there be three resistances R_1 , R_2 , R_3 connected in parallel as shown in Fig. 10.7. One end of each resistance is connected to point A and the other end of each resistance is connected to the point B.

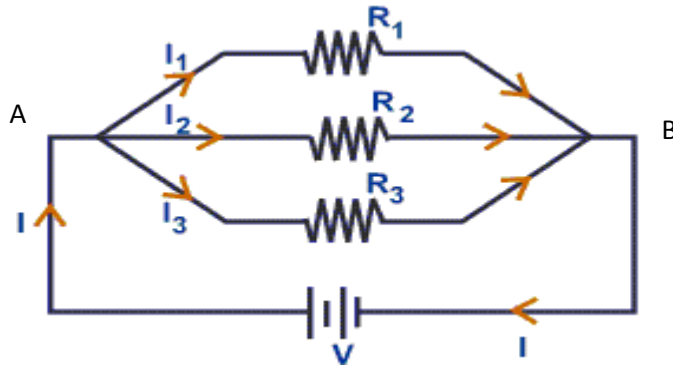

Figure 10.7

Let

V = potential difference applied across A and B (same across each resistance)

I = total current flowing in the circuit.

R = total resistance of the circuit

Let I_1, I_2, I_3 be the current passing through the resistances R_1, R_2, R_3 respectively.

From Ohm's law applied to the whole circuit

$$I_1 = \frac{V}{R_1}$$

$$I_2 = \frac{V}{R_2}$$

$$I_3 = \frac{V}{R_3}$$

Now we have,

$$I = I_1 + I_2 + I_3 \quad \text{..... (2)}$$

Putting the values of I, I_1, I_2, I_3 in the equation (2)

$$\frac{V}{R} = \frac{V}{R_1} + \frac{V}{R_2} + \frac{V}{R_3}$$

$$V \frac{1}{R} = V \left(\frac{1}{R_1} + \frac{1}{R_2} + \frac{1}{R_3} \right)$$

Or
$$\frac{1}{R} = \frac{1}{R_1} + \frac{1}{R_2} + \frac{1}{R_3}$$

Thus we can say that if the resistances are connected in parallel, then the reciprocal of the equivalent resistance is equal to the sum of reciprocals of individual resistances in the circuit.

10.5 HEATING EFFECT OF ELECTRIC CURRENT

When an electric current is passed through a conductor, the conductor becomes hot after some time and produces heat. This effect of electric current is called heating effect of current. This happens due to the conversion of some electric energy passing through the conductor into heat energy.

The heating effect of current was studied experimentally by Joule in 1941. After doing this experiments, Joule came to the conclusion that the heat produced in a conductor is

directly proportional to the product of square of current (I^2), resistance of the conductor (R) and the time (t) for which current is passed. Thus,

$$H = I^2 R t$$

Derivation of Formula

To calculate the heat produced in a conductor, consider current I is flowing through a conductor of resistance R for time t . Also consider that the potential difference applied across its two ends is V .

Now, total amount of work done in moving a charge q from point A to point B is given by:

$$W = q \times V \quad \text{----- (1)}$$

Now, we know that charge = current x time

$$\text{or } q = I \times t$$

$$\text{and } V = I \times R \quad (\text{Ohm's law})$$

Putting the values of q and V in equation (1), we get

$$W = (I \times t) \times (I \times R)$$

$$\text{or } W = I^2 R t$$

Now, assuming that all the work done is converted into heat energy we can replace symbol of 'work done' with that of 'heat produced'. So,

$$H = I^2 R t$$

Applications of Heating Effect of Current

The heating effect of current is used in various electrical heating appliances such as electric bulb, electric iron, room heaters, geysers, electric fuse etc.

10.6 ELECTRIC POWER

Electric power is the rate per unit time at which electric energy is transferred or consumed by an electric circuit.

$$P = \frac{W}{t}$$

$$\text{Or } P = V I$$

Where, V is the applied voltage and I is the current flowing through the circuit. SI unit of power is watt (W).

$$\text{Now } P = V I$$

If, $V = 1$ volt (1 V) and $I = 1$ ampere (1 A), then,

$$P = 1 \text{ watt}$$

Thus, power is said to be 1 watt, if a potential difference of 1 volt causes 1 ampere of current to flow through the circuit.

Bigger units of electric power are kilowatt (kW) and megawatt (MW)

10.7 KIRCHHOFF'S LAWS

These two rules are commonly known as: Kirchhoff's circuit laws with one of Kirchhoff's laws dealing with the current flowing in a closed circuit, Kirchhoff's current law (KCL); while the other law deals with the voltage sources present in a closed circuit, Kirchhoff's voltage law, (KVL).

(i) Kirchhoff's First Law (Kirchhoff's Current Law) KCL

The law states that “The algebraic sum of all the currents meeting at any junction point in an electric circuit is zero”

$$\Sigma I = 0$$

Let us suppose the currents I_1, I_2, I_3 entering the junction are all positives in value and the two currents I_4, I_5 are leaving the junction are negative in values (Fig. 10.8), then according to KCL

$$I_1 + I_2 + I_3 - I_4 - I_5 = 0$$

Or $I_1 + I_2 + I_3 = I_4 + I_5$

or Sum of incoming currents = sum of outgoing currents

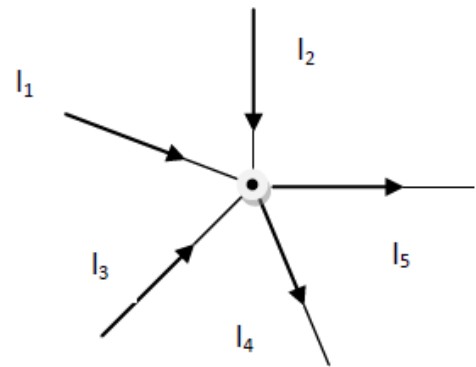

Figure 10.8

(ii) Kirchhoff's Second Law (Kirchhoff's Voltage Law) KVL

The law states that “In any closed loop of a circuit, the algebraic sum of products of the resistances and currents plus the algebraic sum of all the e.m.f. in that circuit is zero”.

In any closed circuit; $\Sigma E + \Sigma IR = 0$

Here we use two sign conventions (Fig. 10.9).

1. If we go from negative terminal of the battery to the positive terminal then there is rise in potential and it is considered positive. And if we go from positive terminal to negative terminal, there is fall of potential and it is considered as negative.
2. If we go with the current, voltage drop is negative and if we go against the current, the voltage drop is positive.

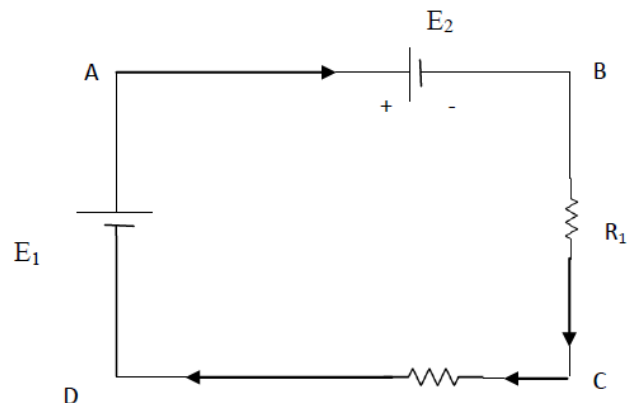

Figure 10.9

In the closed loop ABCD using KVL we get

$$- E_2 - IR_1 - IR_2 + E_1 = 0$$

Solved Numerical

Example 1. An source of emf 6 V is connected to a resistive lamp and a current of 2 ampere flows. What is the resistance of lamp?

Solution. Given, $V = 6 \text{ V}$ and $I = 2 \text{ A}$

From Ohm's law, we know, $V = IR$ or $R = V/I$
 $R = 6/2 = 3\Omega$

Example 2. An electric fan has a resistance of 100 ohms. It is plugged into potential difference of 220 V. How much current passes through the fan?

Solution. Given, $R = 100 \text{ ohm}$ and $V = 220 \text{ V}$

We know, $I = V/R = 220/100$

Therefore $I = 2.2 \text{ A}$

Example 3. Calculate the total resistance, if three resistances of 1 ohm, 2 ohm and 3 ohm are connected in series.

Solution. Given, $R_1 = 1 \text{ ohm}$,

$R_2 = 2 \text{ ohm}$

$R_3 = 3 \text{ ohm}$

We know that in series combination; $R = R_1 + R_2 + R_3$

Therefore $R = 1 + 2 + 3 = 6 \text{ ohm}$

Example 4. Calculate the total resistance if three resistances of 4 ohm, 1 ohm and 6 ohm are connected in parallel.

Solution. Given, $R_1 = 4 \text{ ohm}$

$R_2 = 1 \text{ ohm}$

$R_3 = 6 \text{ ohm}$

Form formula we know in parallel combination

$$\frac{1}{R} = \frac{1}{R_1} + \frac{1}{R_2} + \frac{1}{R_3}$$

Hence
$$\frac{1}{R} = \frac{1}{4} + \frac{1}{1} + \frac{1}{6}$$

Therefore, total resistance, $R = \frac{12}{17} \text{ ohm}$

EXERCISE

Fill in the blanks

- 1) The resistance of the wire is inversely proportional to
- 2) The formula of specific resistance of a wire is
- 3) Product of voltage and current is known as
- 4) SI unit of electric potential is
- 5) SI unit of resistance is
- 6) The reciprocal of conductance is
- 7) SI unit of specific resistance is

Short answer question

1. Define electric current.
2. Define resistance.
3. Define specific resistance.
4. What is conductance?
5. Explain alternating current and direct current.
6. Explain ohm's law.
7. Write short note on electric power.
8. Explain Kirchhoff's laws.
9. If a wire is stretched to double of its length. What will be the new resistivity?

Long Answer type questions

1. Calculate the total resistance when resistances are connected in series and parallel.
2. Explain heating effect of current. Derive the formula for it and what are its applications?
3. a) Three resistors $1\ \Omega$, $2\ \Omega$ and $3\ \Omega$ are combined in series. What is the total resistance of the combination?
b) If the combination is connected to a battery of emf $12\ \text{V}$ and negligible internal resistance, obtain the potential drop across each resistor.
4. Differentiate between AC and DC.
5. Explain Kirchhoff's law of current (KCL) and Kirchhoff's law of voltage (KVL).
6. If the resistance of a circuit is $12\ \Omega$ and the current of $4\ \text{A}$ passes through it calculate the potential difference. [Ans $48\ \text{V}$]
7. Electric fan takes a current of $0.5\ \text{amp}$ when operated on a $200\ \text{V}$ supply. Find the resistance. [Ans $440\ \text{ohm}$]
8. Current of $0.75\ \text{A}$, when a battery of $1.5\ \text{V}$ is connected to wire of $5\ \text{m}$ having cross sectional area $2.5 \times 10^{-7}\ \text{m}^2$, what will be the resistivity?
9. Calculate the total resistance when three resistances of $4\ \text{ohm}$, $8\ \text{ohm}$ and $12\ \text{ohm}$ are connected in series. [Ans $24\ \text{ohm}$]
10. Calculate the total resistance when resistances of $2\ \text{ohm}$ and $2\ \text{ohm}$ are connected in parallel. [Ans $1\ \text{ohm}$]
11. Calculate the power generated in a current of $2\ \text{A}$ passes through a conductor having a potential difference of $220\ \text{V}$. [Ans $440\ \text{W}$]

Chapter 11

ELECTROMAGNETISM

Learning Objectives: After studying this chapter, students will be able to;

- Understand the magnetic field associated with flow of current and related parameters
- Classify materials on basis of magnetic properties
- Describe magnetic flux and magnetic lines of force

11.1 ELECTROMAGNETISM

Electromagnetism or magnetism in general is the study of production of magnetic field when current is passed through a conductor. Various terms associated with magnetism are;

Magnetization (I)

It represents the extent to which a material is magnetized when placed in a magnetic field. It is given by magnetic moment per unit volume of material.

$$I = \frac{M}{V}$$

where, M is magnetic moment and V is volume of the material.

Unit: ampere/metre

Magnetic Intensity (H):

It is the capability of magnetic field to magnetize a magnetic material.

Magnetic Permeability (μ):

It is property of material and defined as the degree to which magnetic lines of force can penetrate the medium.

Magnetic susceptibility (χ):

It is a property which determines how easily a specimen can be magnetised. It is given by ratio of magnetization and magnetic Intensity.

$$\chi = \frac{I}{H}$$

Types of Magnetic Materials:

On the basis of behaviour of magnetic material in magnetic field, the materials are divided in to three categories:

1. Diamagnetic materials:

The materials when placed in magnetic field, acquire magnetism opposite to the direction of magnetic field (Fig. 11.1). The magnetic dipoles in these substances tend to align opposite to the applied field and tend to repel the external field around it.

- Diamagnetic substances have tendency to move from stronger to the weaker magnetic field.

- When rod of diamagnetic material is placed in magnetic field, it aligns perpendicular to the magnetic field.
- Permeability of diamagnetic material is < 1 .

Examples; gold, water, mercury, graphite, lead etc

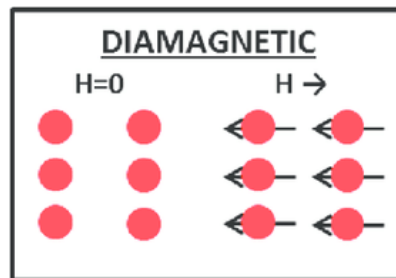

Fig 11.1

2. Paramagnetic materials:

Paramagnetic substances are those which get weakly magnetized when placed in an external magnetic field (Fig. 11.2). These materials show weak attraction in magnetic field. The magnetic dipoles in the magnetic materials tend to align along the applied magnetic field. Such materials show weak feeble magnetization and the magnetization disappears as soon as the external field is removed.

- Permeability of paramagnetic material is > 1 .
- The magnetization (\mathbf{I}) of such materials dependent on the external magnetic field (\mathbf{B}) and temperature (T) as:

$$I = C \frac{B}{T}$$

Where C is the Curie constant.

Examples: sodium, platinum, liquid oxygen, salts of iron and nickel.

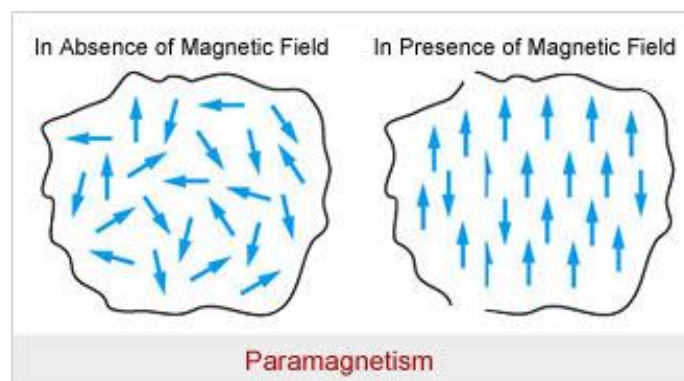

Fig 11.2

Ferromagnetic materials:

Ferromagnetic substances are those which get strongly magnetized when placed in an external magnetic field. They exhibit the strongest attraction in magnetic field. Magnetic dipoles in these materials are arranged into domains.

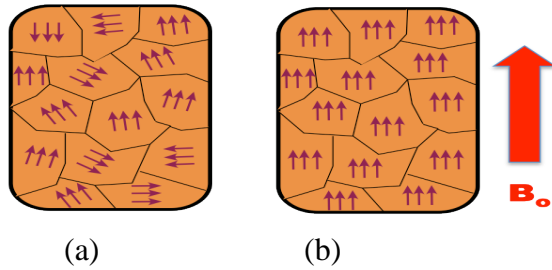

Figure 11.3

These domains are usually randomly oriented as shown in Fig. 11.3 (a) and net magnetism is zero in the absence of magnetic field. When an external field is applied, the domains reorient themselves to reinforce the external field as shown in Fig. 11.3 (b) and produce a strong internal magnetic field that is along the external field. These materials show magnetism on removal of magnetic field.

Examples are iron, cobalt, nickel, neodymium and their alloys. These are usually highly ferromagnetic and are used to make permanent magnets.

11.2 MAGNETIC FIELD

The space around a magnetic material or a moving electric charge within which the force of magnetism can be experienced. The direction of a magnetic field within a magnet is from south to north and outside the magnet is north to south.

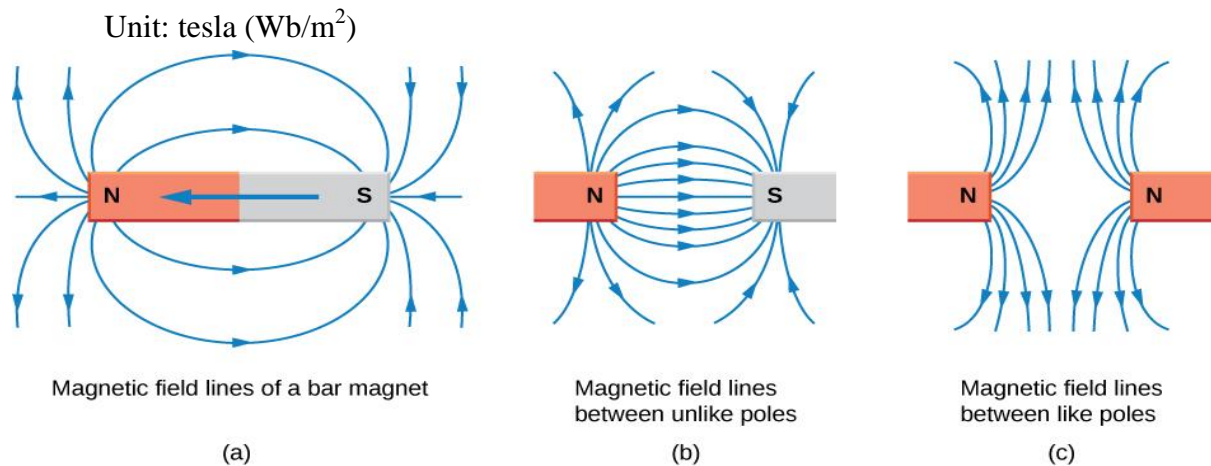

Figure 11.4

Magnetic lines of force:

Curved lines used to represent a magnetic field, drawn such that the number of lines relates to the magnetic field's strength at a given point (Fig. 11.4).

Properties of magnetic lines of force

- (i) The magnetic field lines of a magnet forms continuous closed loops.
- (ii) The tangent to the field line at a given point represents the direction of the net magnetic field (B) at that point.
- (iii) Larger the number of field lines crossing per unit area, the stronger is the magnitude of the magnetic field (B).

- (iv) Their density decreases with increasing distance from the poles.
- (v) The magnetic field lines do not intersect with each other.
- (vi) They flow from the South pole to the North pole within a material and North pole to South pole in air.

Magnetic flux:

The total number of magnetic field lines crossing through given surface area (S) held perpendicular to direction of magnetic field (B).

$$\phi = B S \cos\theta$$

Unit: The SI unit of magnetic flux is the weber (Wb)

Magnetic Intensity:

It is the amount of magnetic flux in a unit area perpendicular to the direction of magnetic flow.

11.3 ELECTROMAGNETIC INDUCTION

The phenomenon of producing an induced e.m.f. in a conductor by changing magnetic flux linked with it is **electromagnetic induction**.

When the speed at which a conductor is moved through a magnetic field is increased, the induced voltage increases and vice versa.

Electromagnetic Induction is used in

- Electrical motor
- Generator to produce AC electricity.
- Induction cooker
- Metal detector
- Inductors and transformers
- Induction welding
- Inductive charging

* * * * *

EXERCISES

Fill in the blanks

- 1) The direction of a magnetic field within a magnet is to
- 2) When the speed at which a conductor is moved through a magnetic field is increased, the induced voltage (increases/ decreases)
- 3) Total number of magnetic field lines passing through an area is called
- 4) Example for para-magnetic materials is
- 5) Example for ferro-magnetic materials

Short Answer type question

1. Define magnetic flux and write its unit.
2. Define electromagnetic induction with example
3. Define magnetic field.
4. What is unit of magnetic field?
5. Define magnetic susceptibility?
Write applications of electromagnetic induction. .
6. Define magnetic field intensity.
7. What is the relation between magnetization and magnetic field?

Long Answer Questions

1. What are magnetic lines of force? Write their properties.
2. Explain type of magnetic materials.
3. Explain ferromagnetic materials with their magnetic domains theory.
4. Explain difference between electric field and magnetic field.
5. Differentiate between paramagnetic and ferromagnetic materials with examples.
6. What is electromagnetic induction? Give its application.

Chapter 12

SEMICONDUCTOR PHYSICS

Learning Objectives: After studying this chapter, students should be able to;

- Understand concept of energy levels and energy bands in solids,
- Describe semiconductor materials, their types and doping,
- Explain semiconductor junctions, junction diodes, and transistors,

12.1 ENERGY LEVEL AND ENERGY BANDS

Energy Levels:

In an atom, electrons cannot revolve in any direction, but are confined to well defined energy states. These states are called *energy levels*.

There are three types of energy levels:

1. **Ground level:** This refers to the lowest energy state in the system (E_0). Thus the completely de-excited atoms would occupy this level.

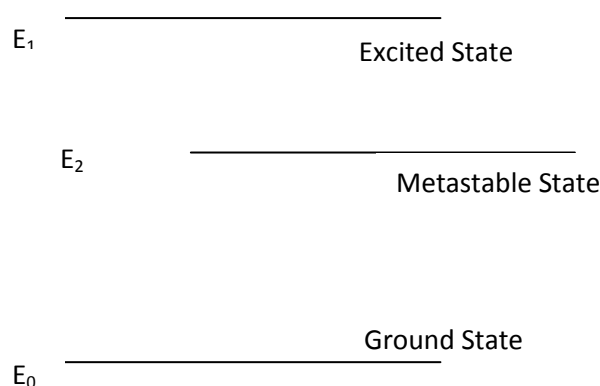

2. **Excited level:** any level above the ground state is excited state (E_1). The atom can stay in excited state only for 10^{-8} s. After this time the atom will lose its energy in the form of radiation and come back to ground state.
3. **Metastable level:** This level (E_2) lies in between the excited (E_1) and ground levels (E_0). Its lifetime is 100 times more than excited state.

Energy bands:

If two atoms are brought closer to form a solid, the energy levels get modified due to mutual interactions. Each energy level split into two levels, one having energy higher than the original level and another having lower energy.

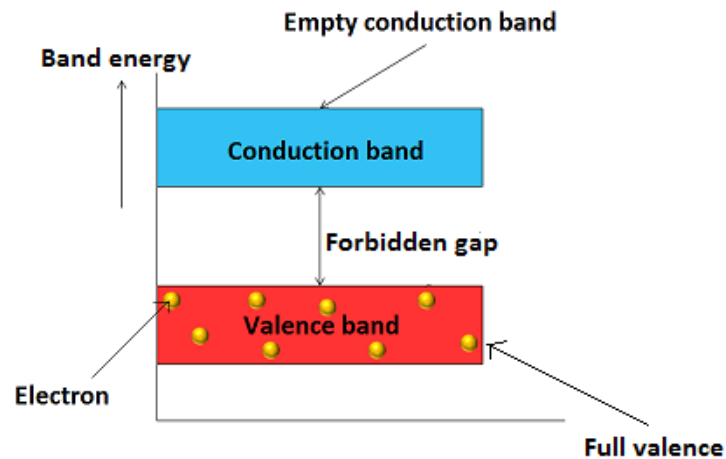

Figure 12.1

Now when a large number of atoms (n) come closer to each other, each energy level splits into a large number of levels. As a result a large number of discrete but closely spaced energy levels are formed. These are called energy bands. The inner shells however remain unaffected by neighbouring atoms, because, they are shielded by the outer electrons of their own atoms.

The highest energy band occupied by the valence electrons is called the **valence band**. Above this band there lies an empty band called the **conduction band**. These bands are separated by an energy gap known as **forbidden gap** (E_g) as shown in Fig. 12.1.

12.2 TYPES OF MATERIALS

On the basis of the forbidden gap (E_g), the material can be divided into following categories (Fig.12.2).

Insulators: These are poor conductors of electricity. Forbidden gap for these materials is $E_g = 5 - 9 \text{ eV}$. The *energy gap between valence band and conduction band is very large*. Hence valence electrons will not be freed and no current will flow. Examples are paper, wood, plastics etc.

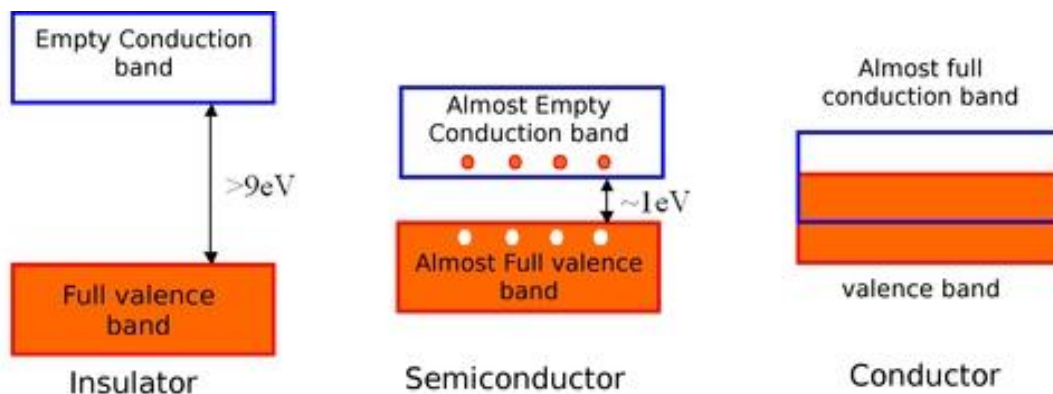

Figure 12.2

Conductors: Metals or good conductors are those substances which can conduct heat and electricity through them easily as there are many free electrons. In case of conductors $E_g = 0$ i.e. *valence band and the conduction band overlap each other*. Examples are Copper, Aluminium, Gold etc.

Semiconductors: The *conductivity of a semiconductor lies between that of conductors and insulators*. In case of semiconductors, E_g is of the order of 1 -2 eV.

At absolute zero temperature, the conduction band is totally empty and there is no flow of current. So these materials act as insulators at room temperature. But at the higher temperature, some valence electrons acquire sufficient energy to go in the conduction band. So at higher temperatures these materials start working as conductors. Even a small electric field can cause a flow of current in such materials. Examples are Silicon (Si), Germanium (Ge).

12.3 INTRINSIC AND EXTRINSIC SEMICONDUCTORS

Intrinsic Semiconductors: A semiconductor, which is quite pure and completely free from any impurity, is called an intrinsic semiconductor. E.g. Silicon (Si) and Germanium (Ge).

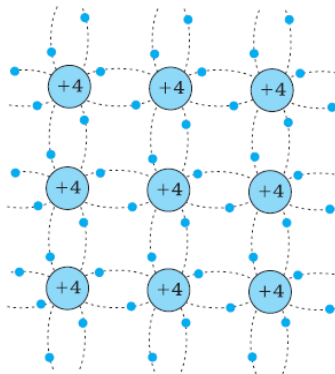

Figure 12.3

They have four valence electrons. Each of the four electrons forms *covalent bond* with neighbouring four atoms. By forming such covalent bonds, there is no free electron at absolute zero temperature. At room temperature some electrons break away from the covalent bond and enter into the conduction band. Each electron leaves behind a vacancy known as hole.

Hence in pure semiconductors both electrons and holes constitute current and the numbers of these two types of charge carriers are equal i.e. $n_e = n_h$

Doping:

The process of adding desirable impurity to a semiconductor is called **doping** and the impurity atoms added are called **dopants**.

Extrinsic Semiconductors

A doped semiconductor is called an extrinsic semiconductor. On the basis of doping, semiconductors are of two types

n-Type Semiconductor:

When a small amount of pentavalent impurity (e.g. Phosphorous, Arsenic etc.) is added to an intrinsic semiconductor (Si or Ge), it provides a large numbers of free electrons. The semiconductor is then, called n-type semiconductor.

Because impurity atom has five valence electrons, four of these will form covalent bonds, but one excess electron will be left free. Hence the current carriers are electrons. Therefore majority carriers are negatively charge electrons while the holes are minority carriers.

In an n-type semiconductor, number of electrons is much larger than the number of holes, i.e. $n_e \gg n_h$

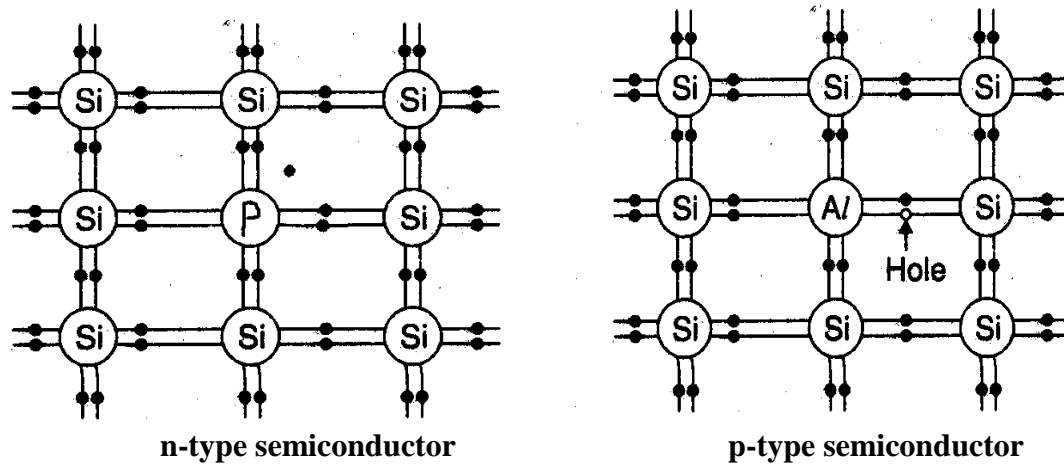

Figure 12.4

p-Type Semiconductor:

When a small amount of trivalent impurity (e.g. Boron, Aluminium etc.) is added to intrinsic semiconductor, it creates a large number of holes in valence band. The semiconductor is called a p-type semiconductor.

When a trivalent impurity is added to semiconductor, its three valence electrons form covalent bonds with three neighbouring atoms, while the fourth bond has a deficiency of electron. Thus there is a vacancy, which acts as a hole that tends to accept electrons.

The number of holes is greater than the number of electrons, i.e. $n_h \gg n_e$. Hence, in p-type semiconductors, holes are the majority carriers and electrons are the minority carriers.

p-n junction Diode

A single crystal of silicon or germanium that has been doped in such a way that half of it is a p-type and the other half an n-type semi-conductor is known as a p-n junction diode. The junction is called p-n junction as shown in Fig.12.5.

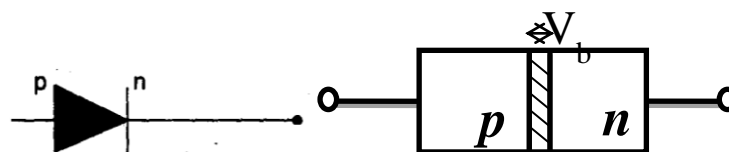

Figure 12.5

Characteristics of p-n Junction Diode

The graph (Fig. 12.7) showing the variation of the current flowing through the junction, when the voltage is applied across the junction diode in forward biased and reverse biased, is known as characteristic curve of a p-n junction diode.

Forward bias characteristic: the p-n junction diode is said to be forward biased if the positive terminal of battery is connected to the p-type and the negative terminal to the n-type of semiconductor as shown in Fig. 12.6.

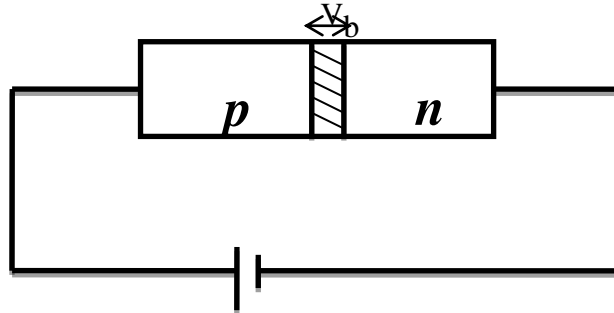

Figure 12.6

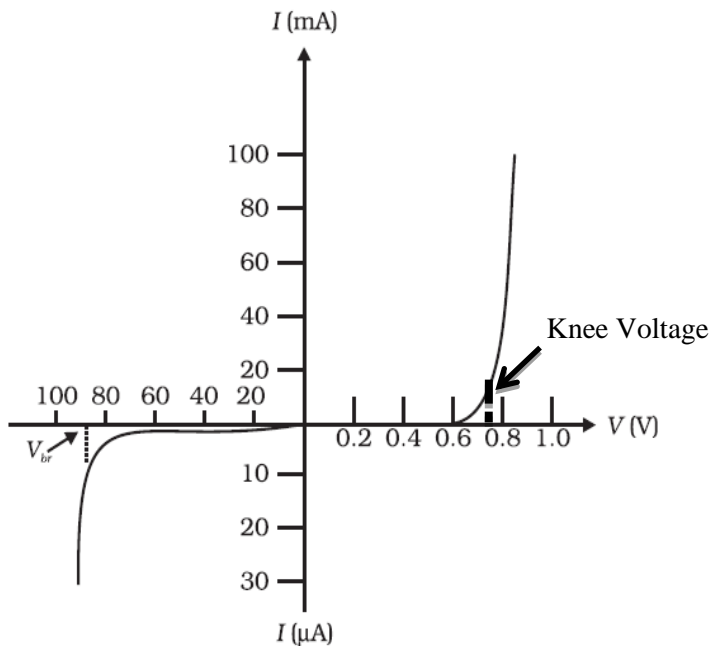

Figure 12.7

Let V is the voltage applied. This pushes the majority carriers, the holes in the p-type and electrons in the n-type towards the p-n junction.

If $V > V_B$, then the majority carriers from both sides are able to diffuse across the junction and a current is set up in the circuit. This process decreases the thickness of the depletion layers. The diode offers a low resistance to the flow of current.

A minimum amount of voltage required so that a current start flowing is known as the knee voltage. The current starts following at point A (knee voltage).

Reverse bias characteristic:

The p-n junction diode is said to be reverse biased if the negative terminal of the external source is connected to the p-type and the positive terminal to the n-type of semiconductor as shown in Fig 12.8.

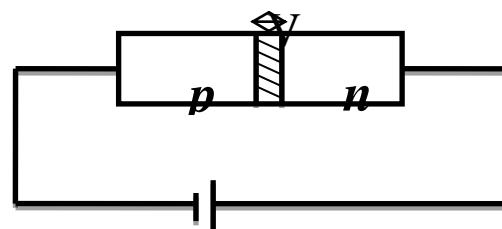

Figure 12.8

The external voltage pulls the majority carriers holes in the p-type crystal and the electrons in the n-type crystal away from the junction. This increases the width of depletion layer. The diode offers very high resistance and no current is set up across the junction due to majority carriers. However, a small current may be there across the junction due to minority carriers. It is called *leakage current* (I_s).

12.4 DIODE AS A RECTIFIER

The rectifier is an electronic device which converts alternating current (AC) into direct current (DC).

Half wave rectifier:

Half wave rectifier convert AC in to DC for only half of the input cycle. The circuit diagram for half wave rectifier using the p-n diode is as shown. During the first half cycle of AC the diode operates under a forward bias and current flows through the load R_L . During the other half, the diode becomes reverse bias and no current flows through the load R_L . Thus we get a rectified, unidirectional current across R_L and only half of the AC signal wave is rectified. The half wave rectifier gives output only for half cycle, hence power loss is high.

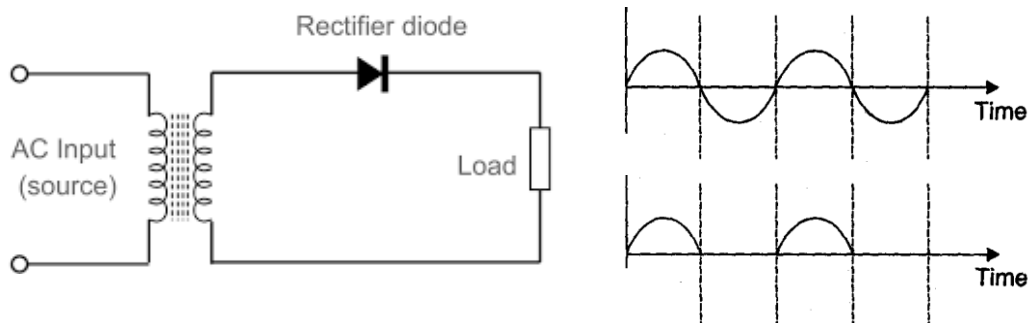

Figure 12.9

Full wave rectifier:

Full wave rectifier converts AC in to DC for complete cycle of input wave. The circuit diagram for full wave rectifier is shown. The center tap transformer is used. Two diodes are connected across the secondary of the transformer, the middle point of which is tapped at T. During the first half of the AC cycle, one end of the secondary say A becomes positive and B becomes negative. Diode D_1 is forward biased and diode D_2 is reverse bias. Thus a current flows through the diode D_1 and output is obtained across R_L .

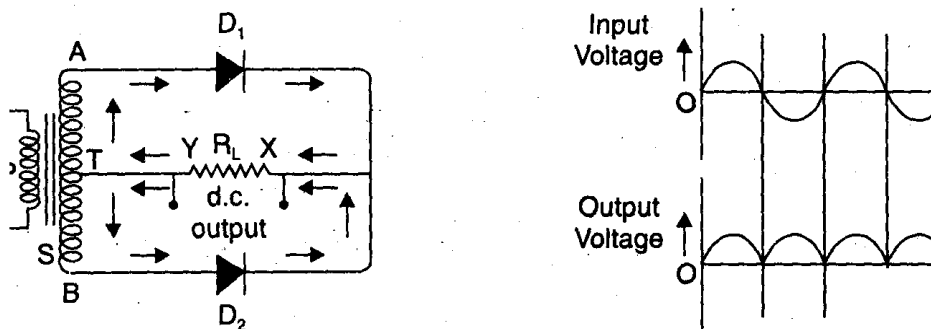

Figure 12.10

Now, during the other half of AC cycle, end B becomes positive and the end A becomes negative and the current flows through the diode D_2 . Thus, during both halves, the current through the load R_L is in the same direction and full wave rectification of AC is achieved.

12.5 SEMICONDUCTOR TRANSISTOR

The transistor is composed of three semiconductor elements. One type of semiconductor is sandwiched between two types of semiconductors. So, basically transistor is combination of two pn-junctions joined back to back (Fig. 12.11). If n-type semiconductor is sandwiched between two p-type semiconductors, this is known as p-n-p transistor.

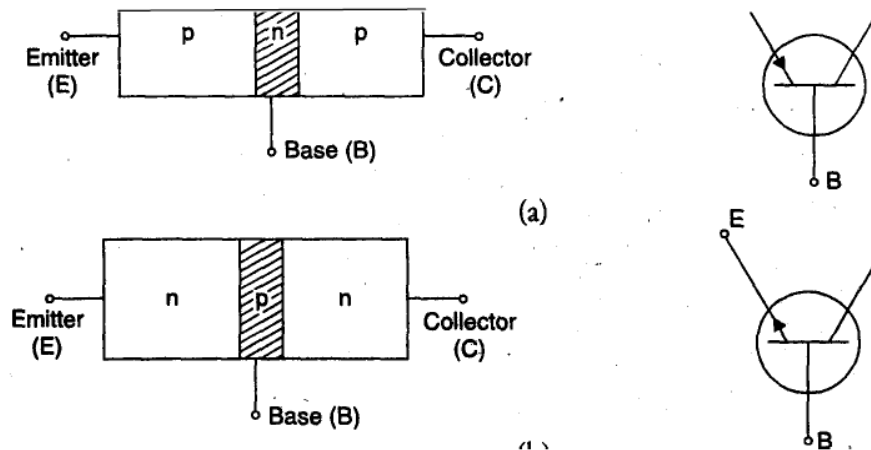

Figure 12.11

If p-type semiconductor is sandwiched between two n-type semiconductors then this is known as n-p-n transistor. In the circuit symbols of a transistor, only emitter has an arrow to indicate that it is the supplier electrode. It also indicates the direction of flow of current.

- The three elements of the transistor are; emitter (E), collector (C) and base (B).
- The emitter supplies the majority carriers for transistor current flow. The collector collects current and the base controls the passage of electrons from the emitter to collector.
- The doping level in the emitter is more than in the collector.
- The base is thin and lightly doped.
- Collector is moderately doped.
- Area of emitter is moderate, for base is minimum and of collector is maximum.
- In normal operation of a transistor, the emitter-base junction is always forward biased whereas the collector-base junction is reverse biased.

* * * * *

EXERCISES

Fill in the blanks

- 1) The diode is nonconducting in biased.
- 2) When the diode current is large, the bias is
- 3) The knee voltage of a diode is approximately equal to
- 4) In an n-p-n transistor, the majority carriers in the emitter are
- 5) The emitter junction is usually biased
- 6) In a p-n-p transistor, the major carriers in the emitter are

Short answer Questions

1. What do you mean by energy level?
2. Define energy band.
3. What do you mean by forbidden gap?
4. Explain conduction and valance band in material?
5. Write the unit used for measuring Forbidden gap?
6. What is forbidden gap for Si, Ge?
7. Explain type of material on the basis of Energy band.
8. Differentiate between a conductor and an insulator.
9. Define semiconductor with example
10. Define doping.
11. What are dopants?
12. Explain p- type semiconductors?
13. Explain n- type semiconductors?
14. Define intrinsic semiconductor?
15. Define extrinsic semiconductor?
16. What is p-n junction diode?
17. Define rectifier?
18. Define transistor.
19. What is n-p-n transistor? Draw symbol.
20. What is p-n-p transistor? Draw symbol.
21. A transistor has how many pn junctions?

Long answer Questions

1. Distinguish between conductors and semiconductors.
2. What is meant by energy band? How is it formed?
3. What does doping mean? How do we obtain the p and n type semiconductor?
4. What is the difference between intrinsic and extrinsic semiconductors?
5. What do you understand by forward biasing and reverse biasing in the operation of a p-n junction diode?
6. Explain transistor? Distinguish between p-n-p and n-p-n transistors.
7. Draw symbols for p-n-p and n-p-n transistors.
8. Write examples of trivalent and pentavalent impurities used as dopant.

9. Write difference between p-type and n-type semiconductors?
10. Define conductor, insulator and semiconductor with example.
11. Explain half wave rectifier.
12. Explain in brief about p-n-p and n-p-n transistor
13. Define rectifier? Explain full wave rectifier with a circuit diagram.
14. Explain p-n junction diode? Plot and explain its characteristics.

Chapter 13

MODERN PHYSICS

Learning objectives: *After studying this chapter, the student should be able to;*

- *Understand concepts of Laser, emission processes and lasing conditions;*
- *List laser beam characteristics and engineering applications.*
- *Describe Optical Fibre, its structure, working principle and applications.*
- *Acquire some knowledge about Nanotechnology and its long term applications.*

13.1 LASER

LASER is an acronym for **Light Amplification by Stimulated Emission of Radiation**. It is a beam of light which is coherent, monochromatic, highly directional and very intense.

Energy Level: In an atom, the electrons are confined to well defined energy states. These states are called as energy level (Fig. 13.1).

There are three types of energy levels:

1. **Ground level:** This refers to the lowest energy state in the system (E_0). The completely de-excited atoms would occupy this level.

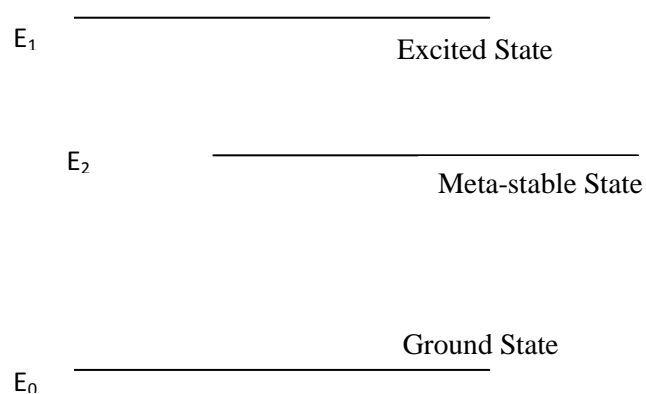

Figure 13.1 Energy levels

2. **Excited level:** Any level above the ground state is excited state (E_1). The atom can stay in excited state only for a very short time varying from 10^{-8} to 10^{-10} second. After this time the atom will lose its energy in the form of radiations and come back to ground state.
3. **Metastable level:** This level lies in-between the excited and ground levels (E_2). Its lifetime is 100 times more than excited state and atom can stay in this state for a longer time.

The Emission Process

When a material is energized by some radiations, the atoms of the material get excited to the higher state from ground state. These excited atoms may lose energy and come back to ground state. The energy loss may be in the form of heat, light or X-rays etc. This process may takes place in two ways:

I. Spontaneous Emission:

Spontaneous emission is the process of light emission in which the atoms in excited state (E_1) comes back to ground state (E_0) after 10^{-8} seconds, without any external radiation(see Fig.13.2).The atoms in excited state, release radiation of energy $h\nu = E_1 - E_0$ in the form of photons. These photons are emitted in random directions.



Figure 13.2 Spontaneous emission process

II. Stimulated Emission:

If excited atom is irradiated with a photon having energy $h\nu = E_1 - E_0$ before spontaneous emission process, then the excited atom will lose the energy in the form of two photon as shown in Fig.13.3. This process occurs in such a way that the incident photon and the emitted photon are found to be moving with same momentum and phase. This kind of emission is called stimulated emission.

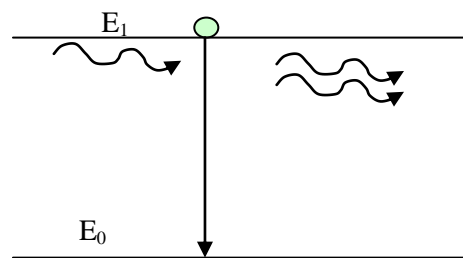

Figure 13.3 Stimulated emission process

Population Inversion:

In a material, when the number of atoms in excited state (N_2) becomes more than the number of atoms in ground state (N_1), this condition is known as population inversion. This condition is must for stimulated emission and hence for Laser emission.

Characteristics of Laser

Laser light has four unique characteristics that differentiate it from ordinary light:

a) Coherence

The photons emitted from ordinary light sources have different phases and hence non-coherent. While in Laser all the emitted photons have same phase or constant phase difference. Thus the laser light is highly coherent in nature. Because of this coherence, a large amount of power can be concentrated in a narrow space.

b) Monochromatic

In laser, all the photons emitted have the same frequency, or wavelength. Hence, the laser light has single wavelength or color. Therefore, laser light covers a very narrow range of frequencies or wavelengths. Hence the light emitted by a laser is highly monochromatic.

c) Directionality

In ordinary light sources (lamp, torch), photons will travel in random direction. Therefore, these light sources emit light in all directions. But, in laser, all photons will travel in same direction. Therefore, laser emits light only in one direction. This is called directionality of laser light. As a result, a laser beam can travel to long distances without spreading.

If an ordinary light travels a distance of 2 km, it spreads to about 2 km in diameter. On the other hand, if a laser light travels a distance of 2 km, it spreads by less than 2 cm.

d) High Intensity

In laser, the light spreads in small region of space and in a small wavelength range. Hence, laser light has greater intensity when compared to the ordinary light. Even 1 mW laser would appear many thousand times more intense than 100 W ordinary lamp.

Applications of Lasers:

- **Laser welding:** Lasers can be used for spot welding, seam welding, inert gas laser welding and welding of non-metals.
- **Laser cutting:** Metals can be cut with output power of atleast 100 W to 500 W. Wide range of materials can be cut e-g. paper, cloth, plywood, glass, ceramics, sheet metal like steel, titanium, aluminium etc.
- **Laser drilling:** Lasers are used for fine drilling
- Lasers are used for accurate measurement of the order of 0.1 m to the extent of distant object.
- Lasers are used to produce thermonuclear fusion.
- These are used to study the chemical process, nature of chemical bonds, structure of molecule and scattering.
- Long distance communication by using optical fibre and laser is very efficient.
- In medicine, lasers are used to study many biological samples, treatment of liver and to remove tumors.
- Laser is used for printing. Laser printers are very fast and efficient. The quality is very high.
- In computers, we use laser disc. In CD writer, a tiny laser beam burns spot on the compact disc.

13.2 OPTICAL FIBRE

An optical fibre consists of a very thin core made of glass or silica having a radius of the order of micrometers (10^{-6} m). The core is covered by a thin layer of cladding material of lower refractive index. Such optical fibres can transmit a light beam from one end to the other without significant energy loss. These are generally made from transparent materials such as glass (silica) or glass like polymers.

*The branch of physics dealing with the propagation of light through optical fibres is known as **fibre optics***

Principle: It is based on the phenomenon of *total internal reflections* at the glass or silica boundary. The light will reach at other end even if the fibre is bend or twisted.

If ray of light travelling from a denser medium into a rarer medium and the angle of incidence is greater than the critical angle, the ray is totally reflected back into the same media. This phenomenon is called as **total internal reflection**.

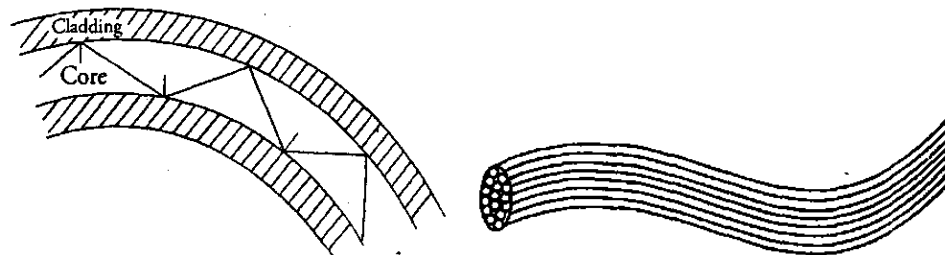

Figure 13.4 Schematic of optical fibre

Fibre Types

On the basis of mode of propagation the fibre can be classified as:

Monomode fibre: It has a very narrow core of diameter about 8-12 μm or less and the cladding is relatively big 125 μm as shown in Fig. 13.5 (a). As the name implies, monomode fibre sustains only one mode of propagation that is why it is also known as single mode fibre,

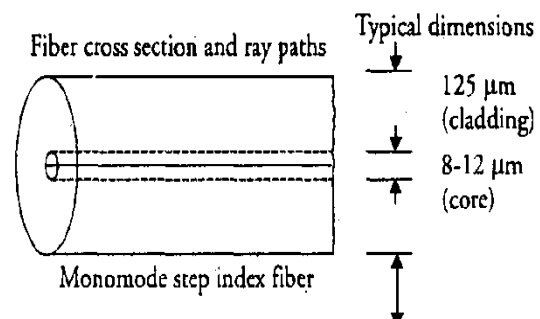

Fig. 13.5 (a)

Multimode fibre: It has a core of relatively large diameter such as 50-200 μm as shown in Fig.13.5 (b). As the name suggests the multimode fibre contain many hundreds of modes of propagation simultaneously. The signals do not intermix with each other. This is most commonly used optical fibre

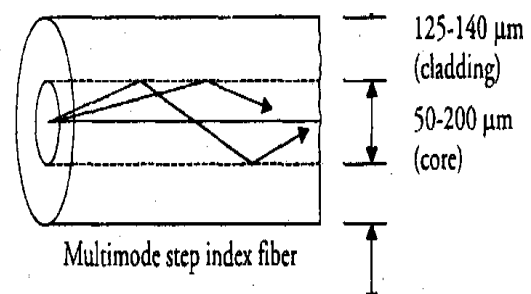

Fig. 13.5 (b)

Numerical Aperture (NA): It is the light collecting ability of an optical fiber. It depends on difference in refractive index of core and cladding. Generally, value of NA ranges from 0.1 to 0.5 for most of the commonly used optical fibres.

Applications of Optical Fibres:

- With the help of light pipes made up of flexible optical fibres, it is possible to examine the inaccessible parts of equipment or of the human body. For example in endoscopy, a patient's stomach can be viewed by inserting one end of a light pipe into the stomach through mouth.
- Optical fibres are also used for transmitting and receiving electrical signals that are converted to light by transducers.
- These are used as transmission medium to transmit communication signals at high data rates over long distances. For example, more than 100000 telephone signals at data rate of Gigabits/sec can be simultaneously transmitted through a typical single pair of optical fibre.
- Optical fibres are also being extensively used for cable TV networks and local area networks (LAN) in premises.

The quality of the signals transmitted with optical fibres is much better than other conventional methods.

13.3 NANOTECHNOLOGY

It is the branch of technology that deals with use of nanomaterials with dimensions less than 100 nanometres, especially the manipulation of individual atoms and molecules.

Nanomaterials:

These are materials with any dimension in the nanoscale (1 nm to 100 nm). These materials are very reactive and exhibit unique physical, chemical and biological properties due to high surface-to-volume ratio.

Example: Carbon nanotube, nanoparticle, quantum dots, nanopolymers, nanoshell, nanopores, nanorod, nanowires, nanopowder, fullerene, etc.

Applications of Nanotechnology

Nanomaterials are of interest because of their unique optical, magnetic, electrical, and other properties. These emergent properties have the potential for great impacts in electronics, medicine, and other fields.

- **Medicine:** Nanotechnology based drugs are being used to treat dangerous diseases like cancers and prevent health issues more effectively, as customized nanoparticles can deliver drugs directly to diseased cells in the body. New nanoparticles based chemotherapy drugs that can be delivered directly to cancer cells for better treatment are under development.
- **Electronics:** Electronic devices made with nano-fabrication techniques help in reducing weight and power consumption. This also improves display screens on electronic devices and increasing the density of memory chips. Nanotechnology can help to reduce the size of transistors and other components used in integrated circuits.
- **Food Industry:** Developing new nanomaterials will not only make a difference in the

taste of food, but also in improve the food production, nutrient value and preservation.

- **Fuel Cells:** Nanotechnology is being used to reduce the cost of catalysts, used in fuel cells to produce hydrogen ions from fuel such as methanol. Nanomaterials are also being developed to improve the efficiency of membranes used in fuel cells.
- **Solar Cells:** Nanotechnology based solar cells can be manufactured at significantly lower cost with better efficiency as compared to conventional solar cells.
- **Space:** Advancements in development of nano- composites make lightweight spacecrafts. Carbon nano-tubes based cables have been proposed for the space elevators.
- **Fuels:** Nanotechnology can be used for production of fuels from low grade raw materials which are economical and also increase the efficiency of engines.
- **Catalyst:** Nanoparticles have a greater surface area to interact with the reacting chemicals than catalysts made up of larger particles. This allows more chemicals to interact with the catalyst simultaneously and hence makes the catalyst more effective.
- **Chemical Sensors:** Nanotechnology based sensors can detect very small amounts of chemical vapours. Various types of nanostructures such as carbon nano-tubes, Graphene, Zinc oxide nanowires can be used as detecting elements in nanotechnology based sensors.
- **Fabric:** Making composite fabric with nano-sized particles or fibres allows improvement of fabric properties without a significant increase in weight, thickness, or stiffness.
- **Environment:** Nanotechnology is being used in cleaning water and existing pollution, improving manufacturing methods to reduce the generation of new pollution, and making alternative energy sources more cost effective.

* * * * *

EXERCISE

Fill in the Blanks

- 1) When number of atoms become more in higher energy levels than lower energy levels, the condition, is called
- 2) In laser, the light amplification is achieved due to (spontaneous/stimulated) emission.
- 3) A multimode step index fibre has a core diameter of range
- 4) For total internal reflection, the angle of incidence is than critical angle
- 5) The size range of nanoparticles is betweento nm.

Short answer Questions

1. Define energy level.
2. Give full form of LASER.
3. What is principle of laser?
4. What is meant by population inversion?
5. Write working principle of optical fibre?
6. Name the type of optical fibres.
7. What are nanomaterials? Give an example.
8. What is size range of nanomaterial?

Long answer Questions

1. Explain the characteristics of laser. Also differentiate between laser beam and ordinary light beam.
2. Describe the two processes of emission of radiations. Also Distinguish between two emission processes.
3. What is the primary requirement to produce laser beam? What are the main properties of laser beam?
4. Write five applications of laser light.
5. Write some uses of optical fibres.
6. Define nanotechnology? Give and explain five applications of nanotechnology

Subject: Applied Physics (180013)

Assignment – 1 (Section A)

Q1: Each Question carries 2 marks.

- i. Write the SI unit of force, work, energy, pressure and momentum.
- ii. Write dimensional formula of distance, displacement, density, force, stress, work, momentum, velocity, strain, acceleration, impulse, surface tension, coefficient of viscosity.
- iii. 1 newton = _____ dynes.
- iv. State the principle of homogeneity
- v. Write cgs units of length, mass and time.
- vi. Write two advantages of SI units over the earlier systems.
- vii. Give limitations of method of dimensions.
- viii. Name the fundamental quantities and write their units.
- ix. State triangle law and parallelogram law of vector addition.
- x. What is relation between linear and angular velocity?
- xi. Define velocity and acceleration
- xii. Define Impulse with example.

1. Covert 1 joule into erg using dimension analysis. (4)
2. Define vector and scalar quantity, giving examples in each case. (4)
3. Define the terms vector product and scalar product. Write formula. (4)
4. Define force. What is meant by resolution of force? (4)
5. Define momentum. State conservation of liner momentum. (4)
6. Define centripetal and centrifugal force. Write formula (4)
7. State Newton's three laws of motion with example (4)
8. Define angular displacement, angular velocity, angular acceleration, frequency and time period. (8)
9. Define banking of road. Derive an expression for banking of road. (8)

Subject: Applied Physics (180013)

Assignment – II (Section B)

Q1: Each Question carries 2 marks.

- i. Define power. Write its unit.
 - ii. Define energy and write its unit.
 - iii. Define potential energy.
 - iv. Define work. Give unit of work
 - v. Define stress. Give its SI units.
 - vi. State Hooks law.
 - vii. Define elasticity. Give 2 example of elastic material.
 - viii. Define restoring force and deforming force.
 - ix. Give four example of transformation of Energy.
 - x. Define pressure and write its unit.
 - xi. Define streamline and turbulent flow.
 - xii. What is effect of temperature on surface tension?
 - xiii. What is physical significance of moment of inertia?
 - xiv. Define torque with example.
 - xv. What is Pascal law?
-
1. State kinetic energy. Find the expression for it. (4)
 2. Define strain. Explain its types. (4)
 3. Define radius of gyration. Derive expression for it. (4)
 4. Define angular momentum. What is conservation of angular momentum? (4)
 5. Define moment of inertia with example. (4)
 6. Define surface tension and give its unit. Write three applications of surface tension? (4)
 7. Define viscosity. What is the effect of temperature on viscosity?. (4)
 8. State principle of conservation of energy and prove it for freely falling body. (8)
 9. Explain Young's, bulk and shear modulus of elasticity. (8)

Section A: objective types question. All questions are compulsory. (1X10=10)

Question 1

- i. SI unit of temperature is
- ii. Heat is transferred in solids by the mode of
- iii. SI unit of specific resistance is
- iv. Write Full form of SONAR
- v. Diamonds shine brightly due to reflection of light.(True/false)
- vi. A device that converts AC to DC is called
- vii. Resistance of a material isproportional to the area of the conductor.
- viii. The resistance of a semiconductor(increases/decreases) with temperature.
- ix. Light wave is(transverse/longitudinal)in nature.
- x. The sound wave having frequency greater than 20 kHz are called

Section B: Very short answer type questions. Attempt any five questions. (5X2=10)

Question 2

- a) Define convection.
- b) Define coefficient of absorption of sound.
- c) What is power of lens? Write its unit.
- d) Define Ohm's law. Write its formula.
- e) Define electric power. Give its SI unit.
- f) Define electromagnetic induction with example
- g) Draw the symbol of pnp and npn transistor.

Section C: Short answer type questions. Attempt any six questions. (6X4=24)

3. Define echo and reverberation
4. What is total internal reflection? Write the condition for TIR.
5. Write any four principles of measurement of temperature?
6. Define electric potential and write its formula and unit. (2,1,1).
7. State Kirchoff's laws for electrical network
8. Write four differences between longitudinal and transverse wave.
9. Explain about magnetic lines of force? Write their properties.
10. Explain half wave rectifier.

Section D: Long answer type questions. Attempt any two questions. (2x8=16)

11. State and derive Gauss law of electrostatics.
12. What is p-n junction diode? Draw and explain its characteristics.
13. (a) Write any four applications of optical fibre.
(b) Write the characteristic of LASER

Section A: objective types question. All questions are compulsory. (1X10=10)**Question 1**

- i. SI unit of temperature is _____.
- ii. Write full form of S.H.M.
- iii. Name one application of ultrasonic waves.
- iv. Device used to see distant objects is called _____.
- v. Write SI unit of electric charge.
- vi. Write formula of electric flux.
- vii. Frequency of DC is _____.
- viii. Give one example of diamagnetic material.
- ix. Pure semiconductor is also called _____.
- x. Name two parts of optical fiber.

Section B: Very short answer type questions. Attempt any five questions. (5X2=10)**Question 2**

- a) Define critical angle in TIR.
- b) Define cantilever. Write its formula.
- c) Define capacitance. Write its unit.
- d) Define specific resistance. Write its unit?
- e) Define direct and alternating current.
- f) What is the principle of optical fibre.
- g) Define extrinsic semiconductor.

Section C: Short answer type questions. Attempt any six questions. (6X4=24)

3. What is difference between heat and temperature?
4. Drive the relation between velocity, frequency and wave length of electromagnetic wave.
5. Define microscope and telescope. Write two uses of each.
6. Define nanomaterials and give examples. Write two applications.
7. What are electric lines of force? Write their properties.
8. Define reverberation time. What are the methods to control reverberation time?
9. Explain two types of magnetic materials with examples
10. Write four applications of LASER.

Section D: Long answer type questions. Attempt any two questions. (2x8=16)

11. Derive expression for total resistance of resistors connected in (i) Series, (ii) parallel
12. Define rectifier? Explain full wave rectifier with the help of circuit diagram.
13. Name different scales for measuring temperature. Give relation among the scales of temperature.

Section A: objective types question. All questions are compulsory. (1X10=10)

Question 1

- i. What is noise?
- ii. Write lens formula
- iii. SI unit of charge is
- iv. SI unit of electric potential is
- v. What is forbidden gap for Si?
- vi. Give full form of LASER.
- vii. The minimum distance of an obstacle for echo to be heard is 16.6 m. (True / False).
- viii. The size range of nanoparticles is between
- ix. In an npn transistor, the majority carriers in the emitter are
- x. Full form of TIR is

Section B: Very short answer type questions. Attempt any five questions. (5X2=10)

Question 2

- a) Define SHM. Give one example.
- b) A wire has resistance of 64 ohm. What will be its resistance when it is four folded?
- c) What is heating effect of current?
- d) Define magnetic flux and write its unit.
- e) Define refractive index.
- f) Define electric Energy and write its unit.
- g) Define magnetic field

Section C: Short answer type questions. Attempt any six questions. (6X4=24)

3. State and derive Coulomb law of electrostatics.
4. Define electric field. Derive the electric field due to Point Charge
5. What is free, forced and resonant vibration? Give example.
6. Define reflection and refraction. Write laws for them.
7. Explain in brief about PNP and NPN transistor
8. Define conduction & convection method of heat transfer with examples.
9. What is the difference between p-type and n-type semiconductors?
10. Explain any two applications of ultrasonic wave.

Section D: Long answer type questions. Attempt any two questions. (2x8=16)

11. Derive expression for total capacitance of capacitor connected in (i) Series, (ii) parallel.
12. Define displacement, velocity, acceleration, time period and frequency for a particle executing SHM.
13. Define conductors, insulators and semiconductors with example.